



**RICHLAND COUNTY COUNCIL  
REGULAR SESSION AGENDA**

**APRIL 5, 2011  
6:00 PM**

**CALL TO ORDER    HONORABLE PAUL LIVINGSTON, CHAIR**

**INVOCATION     THE HONORABLE GWENDOLYN DAVIS KENNEDY**

**PLEDGE OF ALLEGIANCE   THE HONORABLE GWENDOLYN DAVIS KENNEDY**

**Approval Of Minutes**

1. Regular Session: March 15, 2011 [PAGES 7-17]
2. Zoning Public Hearing: March 22, 2011 [PAGES 19-20]

**Adoption Of The Agenda**

**Report Of The Attorney For Executive Session Items**

3. a. CMRTA Contractual Negotiations
- b. Finch vs. Richland County, et. al.
- c. McEntire vs. Richland County

**Citizen's Input**

4. For Items on the Agenda Not Requiring a Public Hearing

**Report Of The County Administrator**

5. a. Fair Housing Update
- b. Decker Mall Update
- c. Smoking Ban Update [PAGES 24-25]

- d. FEMA Flood Maps Update

### **Report Of The Clerk Of Council**

- 6. a. Palmetto Capital City Classic Roast and Toast Honoring Tony Grant, Thursday, April 21st, Columbia Metropolitan Convention Center, 6:00 p.m. - Reception; 7:00 p.m. - Roast and Toast
- b. 47th Annual Greater Columbia Community Relations Council Luncheon, Wednesday, June 15th, Columbia Metropolitan Convention Center, 12:30-2:00 p.m., Keynote Speaker - City of Columbia Mayor Stephen K. Benjamin

### **Report Of The Chairman**

### **Open/Close Public Hearings**

- 7. a. An Ordinance Amending the Fiscal 2010-2011 General Annual Budget to appropriate \$155,900 of General Fund Undesignated Fund Balance to the Coroner for additional funding for current budget
- b. An Ordinance Amending the Fiscal Year 2010-2011 General Fund Annual Budget to appropriate \$164,754 of General Fund Undesignated Fund Balance to the Solicitor for additional funding for emergency budget request

### **Approval Of Consent Items**

- 8. An Ordinance Amending the Fiscal Year 2010-2011 General Fund Annual Budget to appropriate \$155,900 of General Fund Undesignated Fund Balance to the Coroner for additional funding for current budget [**THIRD READING**] [**PAGES 29-30**]
- 9. 11-03MA  
Ram'on Wideman  
RM-MD to OI (1.38 Acres)  
5326 Ridgeway St.  
09310-05-17/18/19/21/22 [**SECOND READING**] [**PAGE 32**]
- 10. A Resolution in support of Dirt Road Paving Design [**PAGES 34-36**] [**TO TABLE**]
- 11. Fire Station Paving: Drives and Parking [**PAGES 38-40**]
- 12. Shady Wood Lane Improvements Contract [**PAGES 42-43**]
- 13. Fund Balance Designation [**PAGES 45-46**]
- 14. FY 11 General Fund Unemployment Bill [**PAGES 48-49**]
- 15. Neighborhood Stabilization Program Round Three Funds Application [**PAGES 51-53**]
- 16. Fair Housing Proclamation [**PAGES 55-57**]
- 17. Community Development Week Proclamation [**PAGE 59**]

18. Budget Amendment for Risk Management [**PAGES 62-63**]

### **Third Reading Items**

19. An Ordinance Amending the Fiscal Year 2010-2011 General Fund Annual Budget to appropriate \$164,754 of General Fund Undesignated Fund Balance to the Solicitor for additional funding for emergency budget request [**PAGES 65-66**]

### **Report Of Development And Services Committee**

20. Hopkins Community Water System Elevated Tank Color and Logo [**PAGES 68-73**]
21. An Ordinance Authorizing a Utility Easement/Right-of-Way to South Carolina Electric & Gas Company on property identified as TMS # 25600-03-16, also known as 199 Newland Road [**PAGES 75-82**] [**FIRST READING**]
22. Research and give alternative transportation options for released inmates [**PAGES 84-85**]

### **Report Of Administration And Finance Committee**

23. Video Streaming and Rebroadcast of Council Meetings [**PAGES 87-88**]
24. Caughman Creek Property [**UNDER SEPARATE COVER**]

### **Report Of Rules And Appointments Committee**

#### **1. Notification Of Vacancies**

25. Business Service Center Appeals Board-1 [William (Bill) West, May 6, 2011\*]

#### **2. Notification Of Appointments**

26. Community Relations Council-1 [one application was received from Seneca Brewton Henry] [**PAGES 92-93**]
27. Employee Grievance Committee-1 [one application was received from Vivian McCray\*] [**PAGES 95-97**]
28. Planning Commission-1 [applications were received from the following persons: Patrick Palmer; Herbert Sims; Elizabeth Mattos-Ward; Jack R. Ward, Jr.]

#### **3. Discussion From Rules And Appointments Committee**

29. If Council intends to attempt another try at a Referendum for a penny sales tax increase, all council members shall hold public meetings to get public input before making a final decision whether to move forward or not. Public input shall determine how proceeds from the tax will be spent and the term of the tax. This process should be given enough time to make sure it does not appear rushed or at the last minute [**JACKSON**] [**PAGES 99-104**]

Reason:

If approved, the citizens will be paying for this and we are only the representatives of the people's will and so we shall do everything that's in the best interest of the people we serve.

Transparency:

This process whether it is approved and passes or not will give comfort to our constituents that we are not hiding anything by revealing up front everything that would be done with that tax.

30. That all Ordinance changes and text amendments be reflected on the County website no later than 30 days after approval by Council. Presently some ordinance changes that law enforcement may have a need for do not reflect current wording **[MALINOWSKI]**
31. All motions shall be made from Council members only and any request or modification or amendments from staff should be sponsored by a Council member. All changes or addition to any document shall be highlighted or shown in a different color **[JACKSON]**
32. Manage the number of motions made by Council members during the Motion Period **[LIVINGSTON]**
33. All checkmarks placed for recommendation or denial of a particular item on the Council agenda will require a comment to show why such decision was made (No more blanks) **[MALINOWSKI]**
34. That all meeting Council members are advised of will automatically be placed on those Council members calendars who request this service, whether or not they "accept" the invite **[MALINOWSKI]**
35. In light of some recent FOIA requests staff should create a policy addressing requests stating they are in the interest of the public and, therefore, the requester should not be charged. Just because a media person or attorney makes a request does not automatically make it in the interest of the public. It should be incumbent on the requester to show that **[MALINOWSKI]**
36. Personnel Matter: Evaluation Forms **[PAGES 112-122]**

## **Other Items**

37. **REPORT OF THE CONSOLIDATION - PRIVATIZATION AD HOC COMMITTEE**
  - a. Update: Chairman Norman Jackson
38. **REPORT OF THE REGIONAL RECREATION COMPLEX AD HOC COMMITTEE [PAGES 125-129]**
  - a. M. B. Kahn Construction Company – Work Authorization #2 **[ACTION]**
  - b. Funding Recommendations **[ACTION]**

## **Citizen's Input**

39. Must Pertain to Items Not on the Agenda

## Executive Session

### Motion Period

40. a. I move that County Council amend the Employee Handbook to include sexual orientation and gender identity as a protected class from discrimination in the hiring process for equal employment opportunities [**ROSE**]
- b. Motion that County Council adopt the attached public accommodations ordinance. This ordinance prohibits entities from discriminating against a citizen because of race, color, religion, sex, age, national origin, familial status, handicap/disability, or sexual orientation. This ordinance is an exact replica of what the City of Columbia passed in 2008 and in the interest of prohibiting discrimination in any form and regional consistency I motion that County Council adopt it as submitted [**ROSE**] [**PAGES 131-133**]
- c. Ban smoking within a specified distance from a main entrance of a business or public building [**MANNING**]
- d. To review the Pros and Cons of counting prison and/or jail population in the redistricting calculations [**WASHINGTON**]
- e. Resolution supporting Harvest Hope Food Bank's Hold Out for Hunger Day [**PEARCE**] [**PAGE 134**]
- f. I move that Council direct staff address the proliferation of illegal signs in the County by involving Special Services Department, or any other County departments, to conduct a weekly Tuesday sign sweep along the most littered corridors of the County. All signs, except government and utility signs, in the right-of-way would be considered "litter" and disposed of by the County. In addition, I move that staff work with the Zoning Department to develop a simpler and more effective illegal sign ordinance and bring that back to Council [**HUTCHINSON**]
- g. Richland County adopt the State's travel policy per diem [**JACKSON**]

### Adjournment



# Richland County Council Request of Action

**Subject**

Regular Session: March 15, 2011 [**PAGES 7-17**]

# MINUTES OF



## RICHLAND COUNTY COUNCIL REGULAR SESSION TUESDAY, MARCH 15, 2011 6:00 p.m.

*In accordance with the Freedom of Information Act, a copy of the agenda was sent to radio and TV stations, newspapers, persons requesting notification, and was posted on the bulletin board located in the lobby of the County Administration Building.*

---

### MEMBERS PRESENT:

Chair	Paul Livingston
Vice Chair	Damon Jeter
Member	Gwendolyn Davis Kennedy
Member	Joyce Dickerson
Member	Valerie Hutchinson
Member	Norman Jackson
Member	Bill Malinowski
Member	Jim Manning
Member	L. Gregory Pearce, Jr.
Member	Seth Rose
Member	Kelvin Washington

**OTHERS PRESENT** – Michelle Cannon-Finch, Milton Pope, Tony McDonald, Sparty Hammett, Roxanne Ancheta, Randy Cherry, Stephany Snowden, Tamara King, Melinda Edwards, Larry Smith, Dale Welch, Carl Gosline, John Hixon, Daniel Driggers, Dan Johnson, Buddy Atkins, Bill Peters, Anna Fonseca, e Walters, Michelle Onley

### CALL TO ORDER

The meeting was called to order at approximately 6:04 p.m.

### INVOCATION

The Invocation was given by the Honorable Valerie Hutchinson

## PLEDGE OF ALLEGIANCE

The Pledge of Allegiance was led by the Honorable Valerie Hutchinson

## APPROVAL OF MINUTES

**Regular Session: March 1, 2011** – Mr. Washington moved, seconded by Mr. Rose, to approve the minutes as distributed. The vote in favor was unanimous.

## ADOPTION OF AGENDA

Mr. Pope stated that a Legal Briefing: Hamilton-Owens Airport needed to be added under the Report of the County Attorney for Executive Session.

Mr. Livingston stated that Ms. Dickerson requested to recognize Mr. Derrick Huggins under the Report of the Chairman.

Mr. Manning moved, seconded by Ms. Hutchinson, to adopt the agenda as amended. The vote in favor was unanimous.

## REPORT OF THE COUNTY ATTORNEY FOR EXECUTIVE SESSION MATTERS

- a. Shumaker vs. Richland County
- b. Mitigation Bank Proposal Update
- c. Employee Grievance
- d. Hamilton-Owens Airport

## CITIZENS' INPUT

No one signed up to speak.

## REPORT OF THE COUNTY ADMINISTRATOR

**Mitigation Bank Proposal Update** – This item was taken up during Executive Session.

**Property Acquisition Update** – Mr. Pope stated that the County has entered into a contract with the owners of Decker Mall and begun the due diligence period. Updates will be provided to Council regarding the acquisition.

**Employee Grievance** – This item was taken up during Executive Session.



## REPORT OF THE CLERK OF COUNCIL

Ms. Finch congratulated Councilwoman Dickerson on being chosen as the President-elect of the Women of NaCo.

## REPORT OF THE CHAIRMAN

**CMRTA: Derrick Huggins** – Mr. Derrick Huggins gave a brief overview of the goals for the CMRTA.

## APPROVAL OF CONSENT ITEM

- **An Ordinance Amending the Fiscal Year 2010-2011 General Fund Annual Budget to appropriate \$155,900 of General Fund Undesignated Fund Balance to the Coroner for additional funding for current budget [SECOND READING]**

Mr. Manning moved, seconded by Ms. Hutchinson, to approve the consent item. The vote in was unanimous.

## THIRD READING

**An Ordinance Amending the Richland County Code of Ordinances, Chapter 2, Administration; Article VII, Boards, Commissions and Committees; Section 2-332, Boards, Commissions and Committees Created; so as to create a Richland County Complete Streets Commission, and setting forth the conditions under which said commission shall function and the responsibilities of same** – Mr. Jeter moved, seconded by Ms. Dickerson, to approve this item.

Mr. Washington made a substitute motion, seconded by Mr. Jeter, to amend the language in Sec. I(s)(2) *Membership* by removing “*one (1) representative from District One of the South Carolina Department of Transportation (SCDOT)*” and adding the following language: “*In addition, the South Carolina Department of Transportation (SCDOT) District One Administrator or his/her designee shall serve on the Commission.*” The vote in favor was unanimous.

Mr. Malinowski made a motion to amend Sec. I(s)(4)(e) as follows: “*Develop measures in an attempt to reduce pedestrian and cycling accidents.*” The vote in favor was unanimous.

Ms. Hutchinson moved, seconded by Ms. Dickerson, to approve this item as amended. The vote in favor was unanimous.

## SECOND READING

**An Ordinance Amending the Fiscal Year 2010-2011 General Fund Annual Budget to appropriate \$164,754 of General Fund Undesignated Fund Balance to the Solicitor for additional funding for emergency budget request** – Mr. Washington moved, seconded by Mr. Manning, to approve this item. The vote was in favor.

### REPORT OF RULES AND APPOINTMENTS COMMITTEE

#### I. NOTIFICATION OF VACANCIES

- a. **Township Auditorium—1** – Mr. Malinowski stated that the committee recommended advertising for this vacancy. The vote in favor was unanimous.

#### II. NOTIFICATION OF APPOINTMENTS

- a. **Accommodations Tax Committee—3** – Mr. Malinowski stated that the committee recommended re-advertising for these vacancies. The vote in favor was unanimous.
- b. **Appearance Commission, Landscaper/Landscape Architect—1** – Mr. Malinowski stated that the committee recommended re-advertising for this vacancy. The vote in favor was unanimous.
- c. **Building Codes Board of Adjustments & Appeals, (1) Licensed Contractor and (3) Fire Protection Industry—4** – Mr. Malinowski stated that the committee recommended re-advertising for these vacancies. The vote in favor was unanimous.
- d. **Hospitality Tax Committee—4** – Mr. Malinowski stated that the committee recommended re-appointing Mr. Eddie Green and Mr. Derrick Williams and appointing Mr. Robert Tunell and to re-advertising for the remaining vacancy.

Mr. Washington made a substitute motion, seconded by Mr. Manning, to appoint all four applicants.

<u>For</u>	<u>Against</u>
Jeter	Pearce
Manning	Malinowski
Washington	Jackson
	Hutchinson
	Livingston
	Dickerson
	Kennedy
	Rose

The vote on the substitute motion failed.

The vote was in favor of the committee's recommendation.

- e. **Internal Audit Committee—2** – Mr. Malinowski stated that the committee recommended re-advertising for these vacancies. The vote in favor was unanimous.
- f. **Planning Commission—2** – Mr. Malinowski stated that the committee recommended re-appointing Mr. David Tuttle and appointing Mr. Howard VanDine, III. The vote in favor was unanimous.

### III. DISCUSSION FROM RULES AND APPOINTMENTS COMMITTEE

- a. **Personnel Matter: Evaluation Forms/Job Description** – This item was held in committee to obtain additional information.
- b. **All elected County officials shall be treated equally, no exceptions [JACKSON]** – This item was held in committee to obtain additional information from the maker of the motion.
- c. **If Council intends to attempt another try at a Referendum for a penny sales tax increase, all Council members shall hold public meetings to get public input before making a final decision whether to move forward or not. Public input shall determine how proceeds from the tax will be spent and the term of the tax. This process should be given enough time to make sure it does not appear rushed or at the last minute.**

**Reason: If approved, the citizens will be paying for this and we are only the representatives of the people's will and so we shall do everything that's in the best interest of the people we serve.**

**Transparency: This process whether it is approved and passes or not will give comfort to our constituents that we are not hiding anything by revealing up front everything that would be done with that tax. [JACKSON]** – This item was held in committee to obtain clarity and additional information from the maker of the motion.

- d. **Motion to review Council’s rules and regulations regarding the authority of the Chair, seniority, and possible term limitation in positions and rotations [DICKERSON, JACKSON, MALINOWSKI, AND KENNEDY]** – Mr. Malinowski stated that the committee recommended no changes be made to the Council rules regarding the authority of the Chair and seniority. The vote in favor was unanimous.

The committee further recommended that the Chair serve no more than two consecutive terms and would then not be allowed to serve again for two terms. A discussion took place.

<u>For</u>	<u>Against</u>
Malinowski	Pearce
Jackson	Jeter
Hutchinson	Livingston
Dickerson	Manning
Kennedy	Rose
	Washington

The vote on the committee’s recommendation failed.

- e. **Central Midlands Regional Transit Authority—1** – Mr. Malinowski stated that the committee recommended appointing Mr. John V. Furgess, Sr. The vote in favor was unanimous.

#### OTHER ITEMS

**An Ordinance Amending the Fiscal Year 2010-2011 General Fund Annual Budget to appropriate \$70,000 of General Fund Undesignated Fund Balance to the County Attorney for Redistricting Ad Hoc Committee** – Mr. Washington moved, seconded by Ms. Kennedy, to approve this item. The vote in favor was unanimous.

#### CITIZEN’S INPUT

Mr. Jerry Benedict spoke regarding Club Raw.

**EXECUTIVE SESSION**

=====  
**Council went into Executive Session at approximately 6:49 p.m. and came out at approximately 7:54 p.m.**  
=====

- a. **Employee Grievance** – Mr. Manning moved, seconded by Mr. Malinowski, to uphold the Administrator’s recommendation.

Mr. Washington made a substitute motion to uphold the committee’s recommendation. The motion died for lack of a second.

The vote was in favor.

- b. **Shumaker vs. Richland County** – Mr. Malinowski moved, seconded by Ms. Dickerson, to direct the County Attorney to settle the claim as discussed in Executive Session. The vote in favor was unanimous.

- c. **Mitigation Bank Proposal Update** – Ms. Hutchinson moved, seconded by Mr. Malinowski, to decline the offer of the Hopkins land purchase for mitigation banking purposes.

Mr. Washington made a substitute motion, seconded by Mr. Jackson, to defer this until staff’s provides further information.

<b><u>For</u></b>	<b><u>Against</u></b>
Jackson	Pearce
Livingston	Malinowski
Manning	Hutchinson
Rose	Jeter
Washington	Dickerson
	Kennedy

The vote on the substitute motion failed.

Mr. Manning made a substitute motion, seconded by Mr. Washington, to direct staff to make an offer at the appraised value of \$5,030,000. The substitute motion failed.

<b><u>For</u></b>	<b><u>Against</u></b>
Pearce	Jackson
Malinowski	Livingston
Hutchinson	Manning
Jeter	Rose
Dickerson	Washington
Kennedy	

The vote was in favor of the main motion.

- d. **Hamilton Owens Airport** – No action was taken.

#### **MOTION PERIOD**

**I move that we change whatever is necessary so that the Talking Trash Booklet can read that Yard Trash will be picked up equivalent to 4 hoppers as opposed to 2 hoppers [MANNING]** – This item was referred to the D&S Committee.

**Resolution honoring the Keenan Boys Basketball Team for their consecutive State Championship win [KENNEDY]** – Mr. Pearce moved, seconded by Mr. Malinowski, to adopt a resolution honoring the Keenan Boys Basketball Team for their consecutive State Championship win. The vote in favor was unanimous.

**Explore how procurement decisions can provide an element of advantage to use businesses located in Richland County [MANNING]** – This item was referred to the Economic Development Committee.

**In the interest of regional consistency and public safety, I move that Richland County Council adopt an ordinance (consistent to the City of Columbia) banning texting while operating a motor vehicle [ROSE]** – This item was referred to the D&S Committee.

**To have staff obtain and provide council information as it relates to Richland County Transportation Committee spending to include the number of studies conducted, the amount spent, and the companies that received those amounts [MALINOWSKI]** – This item was referred to the A&F Committee.

**For Richland County Council in conjunction with staff to create a policy that addresses the existing budget of newly elected officials and their possible requests for additional funding [MALINOWSKI]** – This item was referred to the A&F Committee.

**For Richland County Council in conjunction with staff to create a policy that will be adhered to for agencies requesting additional budget funds that will cause a budget amendment [MALINOWSKI]** – This item was referred to the A&F Committee.

**All checkmarks placed for recommendation or denial of a particular item on the Council agenda will require a comment to show why such decision was made (No more blanks) [MALINOWSKI]** – This item was referred to the Rules & Appointments Committee.

**That building requirements relating to environmental issues will require regulations for areas of “pollution” that don’t appear to be considered currently, to include but not limited to: Light pollution based on the amount of lights and**

time a facility will use them, run off pollution from additional vehicle contaminants, lawn chemical use, and other household activities that may have a negative effect on drinking aquifers supplying wells, ozone pollution due to additional vehicle traffic created by the development, and that sewer extensions be considered regarding the negative effect they will have on residents with septic systems who would be required to hook up to public sewer in the event of a malfunction vs. having it repaired/replaced [MALINOWSKI] – This item was referred to the D&S Committee.

That all meetings Council members are advised of will automatically be placed on those Council members calendars who request this service, whether or not they “accept” the invite [MALINOWSKI] – This item was referred to the Rules & Appointments Committee.

In light of some recent FOIA requests staff should create a policy addressing requests stating they are in the interest of the public and, therefore, the requester should not be charged. Just because a media person or attorney makes a request does not automatically make it in the interest of the public. It should be incumbent on the requester to show that [MALINOWSKI] – This item was referred to the Rules & Appointments Committee.

That all Ordinance changes and text amendments be reflected on the County website no later than 30 days after approval by Council. Presently some ordinance changes that law enforcement may have a need for do not reflect current wording [MALINOWSKI] – This item was referred to the Rules & Appointments Committee.

I move to create economic incentives (i.e. special tax credits, etc.) for development in the County’s priority investment areas as well as within a 1 mile radius [MANNING] – This item was referred to the Economic Development Committee.

Manage number of motions made by Council members during the Motion Period [LIVINGSTON] – This item was referred to the Rules & Appointments Committee.

In the interest of co-locating the County and City’s planning, zoning, business licenses, and permitting departments, I move that Chairman Livingston appoint a three member committee, made up of Richland County Council Members, said committee will be entrusted to meet with and discuss co-location of these departments with City Council. This committee will solely be to discuss co-location of these departments to create a “one stop shop” for business here in Richland County [ROSE] – This motion was withdrawn.

I move that staff research the feasibility of Richland County creating a joint or co-locating Economic Development Office with the City of Columbia. Such research to specifically entail discussions with City Manager to determine what resources

**the City would be willing to share (i.e. departmental housing, support staff, etc.)**

**[ROSE]** – This motion was withdrawn.

**All motions shall be made from Council members only and any request or modification or amendments from staff should be sponsored by a Council member. All changes or additions to any document shall be highlighted or shown in a different color [JACKSON]** – This item was referred to the Rules & Appointments Committee.

**Amend the recently passed Heirs Property Ordinance to remove staff's addition that includes: Restrictive Covenants (RC), Hold Harmless Agreement (HHA) and the additional 16ft right of way from 66ft back to 50ft.**

**Note: Legal was supposed to review and approve the HHA and RC prior to Planning Commission and public hearing. It was done after third reading and legal cannot find any reason for those additional burdens and neither can I. 50ft right of way is the standard for ditch sections for two lane roads. This is dirt road and requires a 20ft passage 4ft less than the standard 24ft paved road. [JACKSON]** – This item was referred to the D&S Committee.

**Statement Re: Special Called December 21, 2010 Executive Session:** At its Special Called meeting on December 21, 2010 Council met in Executive Session to discuss the employment status of the Clerk of Council, whose employment agreement expired in November and who, upon expiration of that agreement, was appointed by Council to continue on a month to month basis. In Executive Session, two options were discussed.

Option A was to terminate the Clerk's employment effective close of business March 31, 2011 but, in exchange for a full and complete release of any and all claims, to offer her a position within the County Government to be designated by Council at her current salary so she could remain employed in another capacity and work toward attaining retirement eligibility under the South Carolina Retirement System—which requires a minimum of 28 years of active and constructive service to qualify for full retirement benefits. Option A also called for Council to purchase constructive retirement credit for the Clerk, not to exceed 5 years, if and after she attained 23 years of credited service and desired to retire permanently from Richland County government.

Option B was to terminate the Clerk's employment effective close of business March 31, 2011 and to find a position in Richland County Government to be designated by Council to offer to the Clerk so that she could continue her employment with the County in another capacity at her existing salary if she chose to accept the position offered.

Out of respect to the Clerk, when Council came out of Executive Session, we used the shorthand terminology "Option A" and "B" to describe the motions that were thereafter made in open session. Thus, upon returning to open session the minutes of the December 21, 2010 reflect that "Ms. Hutchinson moved, seconded by Ms. Dickerson, to approve Option B" and that "Mr. Jackson made a substitute motion, seconded by Mr. Washington, to approve Option A." The minutes further reflect that the ensuing vote was



6-5 in favor of substitute motion, Option A, and that a motion to reconsider, was made and failed by a 6-5 vote.

I thought it important that we clarify our 21<sup>st</sup> minutes regarding your vote on “Option A” and “Option B” so there is and will be a public record of what those two options represented. I suggest that this statement be appended as an addendum and/or a clarification to the minutes of the December 21, 2010 meeting.

### ADJOURNMENT

The meeting adjourned at approximately 8:15 p.m.

---

Paul Livingston, Chair

---

Damon Jeter, Vice-Chair

---

Gwendolyn Davis Kennedy

---

Joyce Dickerson

---

Valerie Hutchinson

---

Norman Jackson

---

Bill Malinowski

---

Jim Manning

---

L. Gregory Pearce, Jr.

---

Seth Rose

---

Kelvin E. Washington, Sr.

The minutes were transcribed by Michelle M. Onley

# Richland County Council Request of Action

**Subject**

Zoning Public Hearing: March 22, 2011 [**PAGES 19-20**]

## MINUTES OF



### RICHLAND COUNTY COUNCIL ZONING PUBLIC HEARING TUESDAY, MARCH, 22, 2011 7:00 p.m.

*In accordance with the Freedom of Information Act, a copy of the agenda was sent to radio and TV stations, newspapers, persons requesting notification, and was posted on the bulletin board located in the lobby of the County Administration Building.*

---

---

#### **MEMBERS PRESENT:**

Chair	Paul Livingston
Vice Chair	Damon Jeter
Member	Joyce Dickerson
Member	Norman Jackson
Member	Gwendolyn Davis Kennedy
Member	Bill Malinowski
Member	L. Gregory Pearce, Jr.
Member	Kit Smith
Member	Kelvin E. Washington, Sr.

Absent        Valerie Hutchinson

**OTHERS PRESENT:** Anna Fonseca, Amelia Linder, Milton Pope, Sparty Hammett, Tamara King, Holland Leger, Monique Walters, Michelle Onley

#### **CALL TO ORDER**

The meeting was called to order at approximately 7:02 p.m.

#### **ADDITIONS/DELETIONS TO AGENDA**

A Municipal Annexation Presentation by Mr. Howard Duvall, Executive Director of the Municipal Association was added as Item #3.

## MAP AMENDMENT

### **11-03MA, Ram'on Wideman, RM-MD to OI (1.38 Acres), 5326 Ridgeway St., 09310-05-17/18/19/21/22**

Mr. Livingston opened the floor to the public hearing.

Mr. Ram'on Wideman spoke in favor of this item.

The floor to the public hearing was closed.

Mr. Washington moved, seconded by Mr. Rose, to give First Reading approval to this item. The vote in favor was unanimous.

### **11-04MA, Elias Dib, OI to NC (1.29 Acres), Hardscrabble Rd. & Summer Valley Dr., 17216-10-22**

Mr. Livingston opened the floor to the public hearing.

Mr. Elias Dib and Ms. Saleka Jackson Jones spoke regarding this item.

The floor to the public hearing was closed.

Ms. Kennedy moved, seconded by Mr. Malinowski, to defer this item until the April Zoning Public Hearing. The vote in favor was unanimous.

## PRESENTATION

**Municipal Annexation Presentation, Howard Duvall, Executive Director of the Municipal Association** – Mr. Howard Duvall gave a brief presentation regarding annexations.

## ADJOURNMENT

The meeting adjourned at approximately 7:39 p.m.

Submitted respectfully by,

Paul Livingston  
Chair

The minutes were transcribed by Michelle M. Onley

# Richland County Council Request of Action

**Subject**

- a. CMRTA Contractual Negotiations
- b. Finch vs. Richland County, et. al.
- c. McEntire vs. Richland County

# Richland County Council Request of Action

**Subject**

For Items on the Agenda Not Requiring a Public Hearing

# Richland County Council Request of Action

**Subject**

- a. Fair Housing Update
- b. Decker Mall Update
- c. Smoking Ban Update [**PAGES 24-25**]
- d. FEMA Flood Maps Update



# Richland County Business Service Center

2020 Hampton Street, Suite 1050  
 P.O. Box 192  
 Columbia, SC 29202

Phone: (803) 576-2287  
 Fax: (803) 576-2289  
[bsc@rcgov.us](mailto:bsc@rcgov.us)  
<http://www.rcgov.us/bsc>

## MEMORANDUM

**TO:** J. Milton Pope, County Administrator; County Council

**FROM:** Pam Davis

**DATE:** 3/24/2011

**SUBJECT:** Smoking Ban Report – for December 2010 and 1<sup>st</sup> quarter of 2011

- Number of Complaints Received: 0
- Number of Businesses referenced in complaints: 0
- Business Type(s) referenced in complaints: n/a
  
- Number of Inspections: 14
- Tickets Issued: 7

### Smoking Ban Inspection Log

Date	Name of Business	County Area	Compliant?	Smoking Sign absent?	Smoking present?	# of Customer Tickets	# of Mgt. Tickets	Ashtrays present?
12/15/2010	Jed's Place	South	No	No	Yes	1	1	Yes
2/12/2011	Carolina Bingo	Northeast	Yes	No	No	0	0	No
2/12/2011	Carolina Gold Bingo	Northeast	Yes	No	No	0	0	No
2/12/2011	Five and Dime Bingo	Northeast	Yes	No	No	0	0	No
2/12/2011	Rookies Sports Bar	Northeast	Yes	No	No	0	0	No
2/12/2011	Icy's Sports Bar & Grill	Northeast	Yes	No	No	0	0	No
2/12/2011	Tap's Pub	Northeast	Yes	No	No	0	0	No
2/12/2011	Trackside Tavern*	Northeast	No	No	Yes	0	0	Yes
2/12/2011	C & R Station House*	Northeast	No	Yes	Yes	0	0	Yes



### Smoking Ban Inspection Log

<b>Date</b>	<b>Name of Business</b>	<b>County Area</b>	<b>Compliant?</b>	<b>Smoking Sign absent?</b>	<b>Smoking present?</b>	<b># of Customer Tickets</b>	<b># of Mgt. Tickets</b>	<b>Ashtrays present?</b>
2/12/2011	Wild Wings Café	Northeast	Yes	No	No	0	0	0
3/22/2011	East Room	North	No	No	Yes	1	1	Yes
3/22/2011	EZ Bingo	North	Yes	No	No	0	0	No
3/22/2011	Mr. Bingo	North	Yes	No	No	0	0	No
3/22/2011	Platinum Plus	North	No	No	Yes	2	1	Yes

\* These are private clubs.

# Richland County Council Request of Action

**Subject**

- a. Palmetto Capital City Classic Roast and Toast Honoring Tony Grant, Thursday, April 21st, Columbia Metropolitan Convention Center, 6:00 p.m. - Reception; 7:00 p.m. - Roast and Toast
- b. 47th Annual Greater Columbia Community Relations Council Luncheon, Wednesday, June 15th, Columbia Metropolitan Convention Center, 12:30-2:00 p.m., Keynote Speaker - City of Columbia Mayor Stephen K. Benjamin

# Richland County Council Request of Action

**Subject**

- a. An Ordinance Amending the Fiscal 2010-2011 General Annual Budget to appropriate \$155,900 of General Fund Undesignated Fund Balance to the Coroner for additional funding for current budget
- b. An Ordinance Amending the Fiscal Year 2010-2011 General Fund Annual Budget to appropriate \$164,754 of General Fund Undesignated Fund Balance to the Solicitor for additional funding for emergency budget request

# Richland County Council Request of Action

## **Subject**

An Ordinance Amending the Fiscal Year 2010-2011 General Fund Annual Budget to appropriate \$155,900 of General Fund Undesignated Fund Balance to the Coroner for additional funding for current budget [**THIRD READING**]  
**[PAGES 29-30]**

## **Notes**

February 22, 2011 - The committee recommended that Council approve the request to amend the Coroner's budget by adding an additional \$155,900. The vote in favor was unanimous.

First Reading: March 1, 2011  
Second Reading: March 15, 2011  
Third Reading:  
Public Hearing:

STATE OF SOUTH CAROLINA  
COUNTY COUNCIL FOR RICHLAND COUNTY  
ORDINANCE NO. \_\_-11HR

AN ORDINANCE AMENDING THE FISCAL YEAR 2010-2011 GENERAL FUND ANNUAL BUDGET TO APPROPRIATE \$155,900 OF GENERAL FUND UNDESIGNATED FUND BALANCE TO THE CORONER FOR ADDITIONAL FUNDING FOR CURRENT BUDGET.

Pursuant to the authority granted by the Constitution and the General Assembly of the State of South Carolina, BE IT ENACTED BY THE COUNTY COUNCIL FOR RICHLAND COUNTY:

SECTION I. That the amount of one hundred fifty five thousand nine hundred dollars (\$155,900) be appropriated to FY 2010-2011 Coroner. Therefore, the Fiscal Year 2010-2011 General Fund Annual Budget is hereby amended as follows:

REVENUE

Revenue appropriated July 1, 2010 as amended:	\$ 137,823,215
Appropriation of General Fund undesignated fund balance	<u>155,900</u>
Total General Fund Revenue as Amended:	\$ 137,979,115

EXPENDITURES

Expenditures appropriated July 1, 2010 as amended:	\$ 137,823,215
Increase to Coroner's Current Budget	<u>155,900</u>
Total General Fund Expenditures as Amended:	\$ 137,979,115

SECTION II. Severability. If any section, subsection, or clause of this ordinance shall be deemed to be unconstitutional or otherwise invalid, the validity of the remaining sections, subsections, and clauses shall not be affected thereby.

SECTION III. Conflicting Ordinances Repealed. All ordinances or parts of ordinances in conflict with the provisions of this ordinance are hereby repealed.

SECTION IV. Effective Date. This ordinance shall be enforced from and after \_\_\_\_\_, 2010.

RICHLAND COUNTY COUNCIL

BY: \_\_\_\_\_  
Paul Livingston, Chair

ATTEST THIS THE \_\_\_\_ DAY

OF \_\_\_\_\_, 2010

\_\_\_\_\_  
Michielle R. Cannon-Finch  
Clerk of Council

RICHLAND COUNTY ATTORNEY'S OFFICE

\_\_\_\_\_  
Approved As To LEGAL Form Only.  
No Opinion Rendered As To Content.

First Reading:  
Second Reading:  
Public Hearing:  
Third Reading:

# Richland County Council Request of Action

**Subject**

11-03MA  
Ram'on Wideman  
RM-MD to OI (1.38 Acres)  
5326 Ridgeway St.  
09310-05-17/18/19/21/22 **[SECOND READING] [PAGE 32]**

STATE OF SOUTH CAROLINA  
COUNTY COUNCIL OF RICHLAND COUNTY  
ORDINANCE NO. \_\_\_-11HR

AN ORDINANCE OF THE COUNTY COUNCIL OF RICHLAND COUNTY, SOUTH CAROLINA, AMENDING THE ZONING MAP OF UNINCORPORATED RICHLAND COUNTY, SOUTH CAROLINA, TO CHANGE THE ZONING DESIGNATION FOR THE REAL PROPERTIES DESCRIBED AS TMS # 09310-05-17/18/19/21/22 FROM RM-MD (RESIDENTIAL, MULTI-FAMILY, MEDIUM DENSITY DISTRICT) TO OI (OFFICE AND INSTITUTIONAL DISTRICT); AND PROVIDING FOR SEVERABILITY AND AN EFFECTIVE DATE.

Pursuant to the authority granted by the Constitution of the State of South Carolina and the General Assembly of the State of South Carolina, BE IT ENACTED BY RICHLAND COUNTY COUNCIL:

Section I. The Zoning Map of unincorporated Richland County is hereby amended to change the real properties described as TMS # 09310-05-17/18/19/21/22 from RM-MD (Residential, Multi-Family, Medium Density District) zoning to OI (Office and Institutional District) zoning.

Section II. Severability. If any section, subsection, or clause of this Ordinance shall be deemed to be unconstitutional, or otherwise invalid, the validity of the remaining sections, subsections, and clauses shall not be affected thereby.

Section III. Conflicting Ordinances Repealed. All ordinances or parts of ordinances in conflict with the provisions of this ordinance are hereby repealed.

Section IV. Effective Date. This ordinance shall be effective from and after \_\_\_\_\_, 2011.

RICHLAND COUNTY COUNCIL

By: \_\_\_\_\_  
Paul Livingston, Chair

Attest this \_\_\_\_\_ day of  
\_\_\_\_\_, 2011.

\_\_\_\_\_  
Michielle R. Cannon-Finch  
Clerk of Council

Public Hearing: March 22, 2011  
First Reading: March 22, 2011  
Second Reading: April 5, 2011 (tentative)  
Third Reading:



# Richland County Council Request of Action

**Subject**

A Resolution in support of Dirt Road Paving Design [PAGES 34-36] [TO TABLE]

**Notes**

March 22, 2011 - The committee recommended that Council table this item.

## Richland County Council Request of Action

**Subject:** A Resolution in support of dirt road paving design

### A. Purpose

County Council is requested to consider a Resolution in support of dirt road paving design.

### B. Background / Discussion

Councilman Kelvin Washington made a motion at the February 1, 2011 Council meeting for a resolution in support of dirt road paving design. The Resolution in support of dirt road paving design was submitted by the Richland County Transportation Committee.

### C. Financial Impact

None.

### D. Alternatives

1. Approve the Resolution.
2. Approve an amended Resolution.
3. Do not approve the Resolution.

### E. Recommendation

This request is at Council's discretion.

Recommended by: Councilman Kelvin Washington

Date: February 1, 2011

### F. Reviews

(Please **SIGN** your name, ✓ the appropriate box, and support your recommendation before routing. Thank you!)

#### Public Works

Reviewed by: Don Chamblee

Date:

✓ Recommend Council approval

Recommend Council denial

Comments regarding recommendation:

**Finance**

Reviewed by: Daniel Driggers

Date: 2/12/11

 Recommend Council approval Recommend Council denial

Comments regarding recommendation: Council discretion

**Legal**

Reviewed by: Larry Smith

Date:

 Recommend Council approval Recommend Council denial

Comments regarding recommendation: Council discretion

**Administration**

Reviewed by: Sparty Hammett

Date: 2/16/11

 Recommend Council approval Recommend Council denial

Comments regarding recommendation: Council discretion

A RESOLUTION IN SUPPORT OF DIRT ROAD PAVING DESIGN  
SUBMITTED BY: Richland County Transportation Committee

---

WHEREAS, the most recent study documents that the County maintains dirt and unpaved roads totaling 202 miles in all Districts throughout the County; and

WHEREAS, the Citizens of Richland County residing on these dirt and gravel roads experience lower serviceability and diminished utility from these unpaved roads; and

WHEREAS, airborne dust and particulate matter are aggravated on dirt roads as compared to paved roads and represent undue nuisance which include health and safety hazards for Citizens living in communities having dirt roads; and

WHEREAS, the County invests financial and capital resources on a perpetual basis to maintain service and re-gravel the unpaved road inventory and historically lacks the capital to improve them to traditional road paving standards; and

WHEREAS, the cost to improve unpaved roads to new construction standards as per County Ordinance has been cost prohibitive, resulting in almost no progress being made to pave dirt roads; and

WHEREAS, in 2008, the County engaged an engineering study that developed compelling evidence that led to implementation of new and economical Low Volume Paving Standards that were enacted to Ordinance in 2009; and

RESOLVED, that the Council recognizes the Richland County Transportation Committee's (CTC) offer to provide "C" funds to carry out a pilot design and construction program that includes planning, community involvement engineering design and construction phase for dirt road paving in accordance with new low volume paving Ordinances with mileage to be defined by the CTC based on C-fund levels; and be it further

RESOLVED, that the Richland County Council endorses the CTC's funded effort and selection and pledges that the County will cooperate to the fullest extent practical, will participate and support the project to achieve its goals and objectives.

RESOLVED, the County recognizes the CTC intent to fund this effort without undue delay; and be it further

RESOLVED that the Council adopts this resolution and instructs the Counties support its immediate implementation.

# Richland County Council Request of Action

## **Subject**

Fire Station Paving: Drives and Parking [**PAGES 38-40**]

## **Notes**

March 22, 2011 - The committee recommended that Council approve the request to enter into negotiations and a contract with the lowest responsible bidder, REA Contracting, in the amount of \$254,891.05. The vote in favor was unanimous.

# Richland County Council Request of Action

**Subject:** Fire Station Paving: Drives & Parking

## **A. Purpose**

Council is requested to authorize the Departments of Support Services and Procurement to negotiate and enter into an agreement with the recommended contractor for the purpose of paving the drives and parking for four fire stations. These stations represent the final four stations that were originally constructed without driveway and parking pavement.

## **B. Background / Discussion**

The four fire stations include Congaree Run, Bearcreek, Leesburg, and Gadsden. These current locations have gravel drives and parking areas. These existing areas require pavement to resolve constant maintenance issues and unstable drives during wet weather for emergency equipment. No parking areas will be expanded or reduced in size. Paving with concrete rather than asphalt is planned due to its greater durability, which will greatly reduce future maintenance needs, and due to the high material costs for asphalt. This method was also recommended by the design engineer.

This project is part of a larger project (which was approved by Council in 2006 and following budgets as a multi-year funding strategy) to pave six fire stations originally constructed without pavement for the driveway or parking areas. Two of the six stations were previously paved under this project in 2008. This phase will complete the project by paving the final four stations under one contract to reduce overall project cost.

The design work, as well as the bid documents for this project, was completed by the professional engineering firm, American Engineering Consultants. This company has the necessary expertise and will also oversee the construction phase as part of their scope of work to ensure that the selected contractor meets all specifications, the County's needs and expectations, and all code requirements at these facilities.

Six companies submitted bids for this project. Negotiations, if approved by Council, are to be initiated with REA Contracting, the most responsive, responsible contractor which submitted the lowest bid, to schedule and to complete the work. The Contractor is to perform the work in a manner that will not impact the day to day emergency operations provided from these County assets, and ensure the intent of the design and overall project scope are achieved.

Should negotiations break down the next lowest responder will be contacted to negotiate project requirements and schedules. The difference for alternate #1 for all four fire stations was \$18,003.95 between the two lowest cost responders.

### C. Financial Impact

There are no additional funds requested for project. The funding for this project has already been approved and allocated through a prior budget process and is included in the unencumbered Support Services, Facilities Division's Fire maintenance project budget.

The lowest bid was \$232,891.05 which includes alternate one. (Alternate one is a total \$18,967.95 increase to the overall project, which includes using concrete rather than asphalt for the paving at all four sites.) After including a contingency of \$22,000.00, the total contract would be \$254,891.05 and is within the appropriated approved budget.

#### Bid summary by facility:

Facility	Asphalt Cost	Addendum #1 (Add for Concrete)	Contingency	Facility Total
Gadsden	\$60,370.10	\$4,365.00	\$6,250.00	\$70,985.10
Leesburg	\$62,219.95	\$5,888.55	\$6,250.00	\$74,358.50
Bearcreek	\$29,680.10	\$1,700.40	\$3,250.00	\$34,630.50
Congaree Run	\$61,652.95	\$7,014.00	\$6,250.00	\$74,916.95
Project Totals	\$213,923.10	\$18,967.95	\$22,000.00	254,891.05

### D. Alternatives

1. Approve the request to enter into negotiations and a contract with the lowest responsible bidder, using concrete to complete all paving. This pavement process will reduce maintenance and avoid damage to emergency vehicles from unpaved roads. Additionally, the selection of this alternate provides a long-term solution requiring very little maintenance and greatly reduces maintenance cost in the future.
2. Approve the request to enter into negotiations and a contract with the lowest responsible bidder, using asphalt for paving. While this will lower project costs by \$18,967.95, the use of asphalt will result in much higher maintenance costs over time opposed to the minimal maintenance cost associated with using concrete. Typically, concrete roads have a life span that is four times that of asphalt; 40 years verses 10 years for this type application. Additionally, during the service life of an asphalt pavement, the pavement generally requires frequent repair and patch work, especially in areas that experience heavy loads, such as the ones experienced at fire stations.
3. Do not approve the request and leave the fire stations in their current condition with gravel lots and driveways. This option will risk the stations being inaccessible in inclement weather. Additionally, if the drives remain unpaved, this does create a much higher level of maintenance requirements, costs, and damage to vehicles.

### E. Recommendation

It is recommended that Council approve alternative #1.

Recommended by: John Hixon Department: Support Services, Facilities Date: 03/07/11

## F. Reviews

(Please ***SIGN*** your name, ✓ the appropriate box, and support your recommendation before routing. Thank you!)

### Finance

Reviewed by: Daniel Driggers

Date: 3/8/11

✓ Recommend Council approval

Recommend Council denial

Comments regarding recommendation:

### Emergency Services

Reviewed by: Michael Byrd

Date: 3/10/11

xx Recommend Council approval

Recommend Council denial

Comments regarding recommendation:

### Procurement

Reviewed by: Rodolfo Callwood

Date: 3/10/11

Recommend Council approval

Recommend Council denial

Comments regarding recommendation:

### Legal

Reviewed by: Larry Smith

Date:

✓ Recommend Council approval

Recommend Council denial

Comments regarding recommendation:

### Administration

Reviewed by: Tony McDonald

Date: 3/14/11

✓ Recommend Council approval

Recommend Council denial

Comments regarding recommendation: This project represents the last phase of a long term paving effort for the County's fire stations. Funds are already appropriated for the project. It is, therefore, recommended that staff be authorized to negotiate and enter into a contract for the paving services.



# Richland County Council Request of Action

**Subject**

Shady Wood Lane Improvements Contract [**PAGES 42-43**]

**Notes**

March 22, 2011 - The committee recommended that Council not approve the request to award the construction contract to Cherokee, Inc. in the amount of \$352,000. The vote in favor was unanimous.



## RICHLAND COUNTY

Department of Public Works

C. Laney Talbert Center

400 Powell Road

Columbia, South Carolina 29203

Voice: (803) 576-2400 Facsimile (803) 576-2499

<http://www.richlandonline.com/departments/publicworks/index.asp>



## MEMO

To: Milton Pope, County Administrator  
Fr: David Hoops, Director of Public Works  
Re: Shady Wood Lane Paving (Broad River WWTP Entrance)  
Date: April 1, 2011

The history of this project as I know it is:

1. On Feb. 18, 2009, I received a phone message from Andy Metts, Utility Director, regarding the paving of Shady Wood Lane. Several days later, I was able to reach Andy and he described the work needed. He also indicated that paving had been promised to the area residents when the plant expansion was proposed.
2. A preliminary project cost estimate of \$400,000 was developed and reviewed with Administration.
3. Sparty Hammett inquired of the background of this request of Andy Metts. The following April 16, 2009 email from Andy Metts answered "*As you are aware, this project has been ongoing for several years. When we initially acquired the property for the WWTP expansion, we had to also acquire the permanent right-of-way (ROW) to access the property. This ROW was owned and transferred to the County by the Mungo Company. The County had been maintaining the dirt road currently known as Shadywood Lane for numerous years.*

*Public Works took the lead on securing the ROW. During this acquisition process, I was told that Ralph Pearson, the previous Public Works Director, committed to paving the road once the WWTP construction was complete. I don't have any written documentation that confirms that information but I did hear that verbal commitment on several occasions. Ralph told me that he was going to include this road in the County's paving program and schedule the work as soon as the construction project was complete. Randy Byrd at Public Works may have more information on this subject. He was involved in the ROW acquisition.*

Item# 12

Attachment number 1  
Page 1 of 2

*This information is about the extent of my knowledge on the subject. If you have any questions, please contact me.”*

4. Based upon the commitment to the area citizens that the road would be completed and the operational needs of servicing the Broad River WWTP, a decision was made to add paving Shady Wood Lane to the Roads and Drainage special projects list. Funding was identified at the end of the FY10 budget year and rolled over into Roads and Drainage’s FY11 budget to complete the project. Public Works was directed to proceed with the project. A consultant engineer was contracted to prepare construction plans. Public bids were taken and presented to the D&S committee of Council on March 25, 2011.
5. Ralph Pearson, the previous Public Works Director, was contacted today by Sparty Hammett. Mr. Pearson indicated that he could not recall committing to citizens that the road would be paved; however, from his recollection Andy Metts did initiate the project. Mr. Pearson did indicate that he included it on the County’s paving program, indicating that the ordinance in place at that time was very restrictive and that public interest had to be served. The public interest was access to a publicly owned facility.

I believe this is an important project that should not be compared to other dirt roads in the paving program. This road now experiences 8-10 heavily loaded trucks daily with hauling sludge and supplies. There are also 10 employees located at the facility. In addition, in the event of a natural disaster, the existing unpaved road could be washed out and make it impossible for the trucks to reach the facility. It is very important that a heavy duty all weather road service the Broad River WWTP.

# Richland County Council Request of Action

**Subject**

Fund Balance Designation **[PAGES 45-46]**

**Notes**

March 22, 2011 - The committee recommended that Council approve the request to amend the financial policy and direct staff to comply with reporting requirements. The vote in favor was unanimous.

# Richland County Council Request of Action

**Subject:** Fund Balance Designations

## **A. Purpose**

*Based on the current volatility of the economy, County Council is requested to direct the County Administrator to designate the portion of the General Fund reserve balance necessary to fulfill all known long-term commitments current in place by Council inclusive of funding the on-going operations of the County.*

## **B. Background / Discussion**

In 2008, Richland County Council approved a comprehensive financial policy. The Director of Finance monitors the County compliance to the policy and periodically will make recommendations of amendments for Council to consider as changing financial conditions warrant. One of the key components monitored in considering a recommended policy change is any new or updated accounting standards that are acknowledged by the Governmental Accounting Standards Board (GASB).

Based on the current policy, the general operating fund balance at June 30<sup>th</sup>, 2010 was \$39.6m. Based on the request above we would recommend that additional designations be recorded as follows:

6/30/10 Undesignated FB	\$39.6m	
	(25.5m)	Designate based on County financial policy for required fund balance level
	( 3.7m)	Designate the amount associated with the FY10 continental settlement to be used for Economic Development
	( 7.8m)	Designate the net amount of fund balance estimated to be required for use in FY12&13 to keep general fund at current funding level due to declining and slower growth of non-tax revenues. This considers the use of the estimated millage cap.
	( 1.4m)	authorize the amount of residual funds from the salary account at the end of FY10 be transferred toward the Other Post Retirement Benefit (OPEB) account which is currently underfunded.

6/30/10 amended undesignated FB    \$ 1.2m

## **C. Financial Impact**

This is a reporting change and will not have a financial impact to the County. It will change the view and interpretation of available fund balance.

**D. Alternatives**

List the alternatives to the situation. There will always be at least two alternatives:

- 1. Approve the request to amendment the financial policy and direct staff to comply with reporting requirements.
- 2. Do not approve.

**E. Recommendation**

It is recommended that the County amend the financial policy as stated.

Recommended by: Tony McDonald      Department: Administration      Date: 2/04/11

**F. Reviews**

(Please **SIGN** your name, ✓ the appropriate box, and support your recommendation before routing. Thank you!)

**Finance**

Reviewed by: Daniel Driggers      Date: 2/4/11  
 ✓ Recommend Council approval       Recommend Council denial  
 Comments regarding recommendation: Recommendation is consistent with the County financial policy and the new Governmental Accounting Standards Board (GASB) pronouncement effective June 30, 2011 for Richland County.

**Human Resources**

Reviewed by: Dwight Hanna      Date:  
 Recommend Council approval       Recommend Council denial  
 Comments regarding recommendation: Human Resources supports actions which are consistent with the County’s financial policy and the new Governmental Accounting Standards Board (GASB) pronouncement effective June 30, 2011 for Richland County.

**Legal**

Reviewed by: Larry Smith      Date:  
 Recommend Council approval       Recommend Council denial  
 Comments regarding recommendation: Council discretion

**Administration**

Reviewed by: Tony McDonald      Date: 2/16/11  
 ✓ Recommend Council approval       Recommend Council denial  
 Comments regarding recommendation:

# Richland County Council Request of Action

**Subject**

FY 11 General Fund Unemployment Bill [PAGES 48-49]

**Notes**

March 22, 2011 - The committee recommended that Council approve staff's request to appropriate fund balance in the amount of \$227,000 for the County's Unemployment bill. The vote in favor was unanimous.

STATE OF SOUTH CAROLINA  
COUNTY COUNCIL FOR RICHLAND COUNTY  
ORDINANCE NO. \_\_-11HR

AN ORDINANCE AMENDING THE FISCAL YEAR 2010-2011 GENERAL FUND ANNUAL BUDGET TO APPROPRIATE \$227,000 OF GENERAL FUND UNDESIGNATED FUND BALANCE TO NON DEPARTMENTAL FOR THE COUNTY'S UNEMPLOYMENT BILL.

Pursuant to the authority granted by the Constitution and the General Assembly of the State of South Carolina, BE IT ENACTED BY THE COUNTY COUNCIL FOR RICHLAND COUNTY:

SECTION I. That the amount of two hundred twenty seven thousand dollars (\$227,000) be appropriated to FY 2010-2011 Non Departmental. Therefore, the Fiscal Year 2010-2011 General Fund Annual Budget is hereby amended as follows:

REVENUE

Revenue appropriated July 1, 2010 as amended:	\$ 137,823,215
Appropriation of General Fund undesignated fund balance	<u>227,000</u>
Total General Fund Revenue as Amended:	\$ 138,050,215

EXPENDITURES

Expenditures appropriated July 1, 2010 as amended:	\$ 137,823,215
Increase to Non Departmental's Current Budget	<u>227,000</u>
Total General Fund Expenditures as Amended:	\$ 138,050,215

SECTION II. Severability. If any section, subsection, or clause of this ordinance shall be deemed to be unconstitutional or otherwise invalid, the validity of the remaining sections, subsections, and clauses shall not be affected thereby.

SECTION III. Conflicting Ordinances Repealed. All ordinances or parts of ordinances in conflict with the provisions of this ordinance are hereby repealed.

SECTION IV. Effective Date. This ordinance shall be enforced from and after \_\_\_\_\_, 2010.



RICHLAND COUNTY COUNCIL

BY: \_\_\_\_\_  
Paul Livingston, Chair

ATTEST THIS THE \_\_\_\_ DAY

OF \_\_\_\_\_, 2010

\_\_\_\_\_  
Michielle R. Cannon-Finch  
Clerk of Council

RICHLAND COUNTY ATTORNEY'S OFFICE

\_\_\_\_\_  
Approved As To LEGAL Form Only.  
No Opinion Rendered As To Content.

First Reading:  
Second Reading:  
Public Hearing:  
Third Reading:

# Richland County Council Request of Action

## **Subject**

Neighborhood Stabilization Program Round Three Funds Application [**PAGES 51-53**]

## **Notes**

March 22, 2011 - The committee recommended that Council approve the request to adopt the incorporation of the Neighborhood Stabilization Program Round III Fund into the Richland County Community Development Block Grant Program as per the Dodd-Frank Wall Street Reform and Consumer Protection Act of 2010. The vote in favor was unanimous.

# Richland County Council Request of Action

**Subject:** Neighborhood Stabilization Program Round Three (NSP-3) Funds Application

## **A. Purpose**

County Council is requested to adopt the incorporation of the Neighborhood Stabilization Program Fund Round III (NSP-3) into the Richland County Community Development Block Grant (CDBG) Program as per the Dodd-Frank Wall Street Reform and Consumer Protection Act of 2010 that was originally established under the Housing and Economic Recovery Act of 2008 (HERA). The funding source is SC State Housing Finance and Development Authority.

## **B. Background / Discussion**

HUD has made an allocation of NSP-3 funds to states and certain local governments. South Carolina State Housing Finance and Development Authority (SCHFDA) received an allocation of \$5,615,020.00 for the entire state of South Carolina. The SCHFDA requested Richland County Community Development to apply for state NSP-3 funding because we are a NSP-1 recipient and there are areas located in Richland County that rank among the highest areas of greatest need in the state. These areas or neighborhoods have severe problems associated with the foreclosure crisis.

All activities funded by NSP-3 must benefit low- moderate- and middle- income (LMMI) households or areas up to 120% of the area median income. Richland County must target these funds to the areas of greatest need within the County and can expend the funds throughout the entire county, if it deems appropriate by the funding source. No more than 10% of the total award can be used for demolition. Thirty percent (30%) of the award must be used to benefit households 50% or below the area median income for rental housing. If funded, the Community Development Department will receive up to 1,319,529.70 from SCHFDA.

The NSP-3 funds can be used for the following eligible areas:

- Establish financing mechanisms for purchase and redevelopment of foreclosed homes and residential properties;
- Purchase and rehabilitate homes and residential properties abandoned or foreclosed;
- Demolish blighted structures;
- Redevelop demolished or vacant properties

The Census Tracts to be addressed include: CT 5, 107.03, 110 which fall within Council Districts 3 and 4. This was based upon the HUD based need score calculated by HUD using marketing conditions and other factors.

## **C. Financial Impact**

The Richland County General Budget should incur no financial impact with the NSP-3 funds. No matching funds will be required from the County on NSP-3. In addition, the NSP-3 program provides administrative costs for the life of program. The proposed budget below lists the distributions of funding.

Proposed Budget

\$131,952.97	10% of award for demolition of unsafe, abandoned housing units
\$395,858.91	30% of award for 50% or below rental housing
\$535,567.62	Homeownership to be completed in areas of high concentration
\$ 200,000.00	Redevelopment to be completed in areas of high concentration
\$ 56,150.20	Administrative Cost for the life of the program
\$1,319,529.70	Total Funding

**D. Alternatives**

1. County Council can approve the request to adopt the incorporation of the Neighborhood Stabilization Program Round III (NSP-3) Fund into the Richland County Community Development Block Grant (CDBG) Program as per the Dodd-Frank Wall Street Reform and Consumer Protection Act of 2010.
2. County Council can not approve the adoption and involvement of the NSP-3 Fund.

If the first option is not selected, Richland County will lose \$1.3 million dollars that would have been granted to Richland County to benefit communities that have foreclosed and abandoned properties. The SCHFDA will redistribute the funds to another high impact county.

**E. Recommendation**

It is recommended that Council approve the request to adopt the incorporation of the Neighborhood Stabilization Program Round III (NSP-3) Fund into the Richland County Community Development Block Grant (CDBG) Program as per the Dodd-Frank Wall Street Reform and Consumer Protection Act of 2010.

Recommended by: Valeria D. Jackson  
Date: 2/7/2011

Department: Community Development

**F. Reviews**

(Please **SIGN** your name, ✓ the appropriate box, and support your recommendation before routing. Thank you!)

**Finance**

Reviewed by: Daniel Driggers

Date: 2/08/11

✓ Recommend Council approval

Recommend Council denial

Comments regarding recommendation:

**Grants**

Reviewed by: Sara Salley

Date: 2/8/11

✓ Recommend Council approval

Recommend Council denial

Comments regarding recommendation:

**Procurement**

Reviewed by: Rodolfo Callwood  
 Recommend Council approval  
Comments regarding recommendation:

Date: 1/8/11  
 Recommend Council denial

**Legal**

Reviewed by: Larry Smith  
 Recommend Council approval  
Comments regarding recommendation:

Date:  
 Recommend Council denial

**Administration**

Reviewed by: Sparty Hammett  
 Recommend Council approval  
Comments regarding recommendation:

Date: 2/17/11  
 Recommend Council denial

# Richland County Council Request of Action

**Subject**

Fair Housing Proclamation [PAGES 55-57]

**Notes**

March 22, 2011 - The committee recommended that Council approve the request to proclaim April as Fair Housing Month and present the proclamation to a HUD representative. The vote in favor was unanimous.

# Richland County Council Request of Action

**Subject: FAIR HOUSING PROCLAMATION**

**A. Purpose**

County Council is requested to adopt a Proclamation recognizing April as Fair Housing Month. The proclamation will be presented to a HUD official during the April 5, 2011 County Council Meeting.

**B. Background / Discussion**

As an Entitlement Community, Richland County Government receives an annual allocation of Community Development Block Grant and HOME Investment Partnership Program funds from the United States Department of Housing and Urban Development (HUD). As a condition of receiving formula based funding the County certifies that it will affirmatively further fair housing. In order to affirmatively further fair housing we conduct an analysis to identify impediments to fair housing choice within the County. We also take appropriate action to overcome the effects of any impediments identified as well as maintain records reflecting the analysis. Among the impediments identified in the 2004 Analysis of Impediments was the lack of education of citizens about the fair housing law and citizen rights that it grants.

April is Fair Housing Month and the County has for the past seven years kicked off the month of April with presenting a Fair Housing Resolution to a HUD representative.

**C. Financial Impact**

There will be no financial impact associated with this request.

**D. Alternatives**

1. Approve the request to proclaim April as Fair Housing Month in the County and present to a HUD representative and affirm the County's commitment to fair housing choice;
2. Do not approve the request to proclaim April as Fair Housing Month;
3. Choose an alternative method such as a published statement from Council

**E. Recommendation**

It is recommended that Council approve the request to proclaim April as Fair Housing Month and present to a HUD representative.

Recommended by: Valeria Jackson      Department: Community Development  
Date: March 1, 2011

**F. Reviews**

(Please **SIGN** your name, ✓ the appropriate box, and support your recommendation before routing. Thank you!)

**Finance**

Reviewed by: Daniel Driggers

Date: 3/8/11

✓ Recommend Council approval

Recommend Council denial

Comments regarding recommendation:

**Legal**

Reviewed by: Larry Smith

✓ Recommend Council approval

Comments regarding recommendation:

Date:

Recommend Council denial

**Administration**

Reviewed by: Sparty Hammett

✓ Recommend Council approval

Comments regarding recommendation:

Date: 3/8/11

Recommend Council denial



STATE OF SOUTH CAROLINA)

FAIR HOUSING PROCLAMATION

COUNTY OF RICHLAND )

RICHLAND COUNTY PROCLAIMS APRIL 2011 AS FAIR HOUSING MONTH

WHEREAS, the Richland County Council recognizes April as National Fair Housing Month and remains strongly committed to affirmatively further fair housing through its policies, building codes and community development programs; and

WHEREAS, the Richland County Council commemorates the enactment of the Title VIII Civil Rights Act of 1968 as amended (Fair Housing Act); and

WHEREAS, the Richland County Council rejects discrimination in the provision of housing on the basis of race, religion, color, sex, national origin, familial status, or disability; and

WHEREAS, the Richland County Council desires that its citizens be afforded Fair Housing Choice without the occurrence of discrimination; and

WHEREAS, the Richland County Council encourages positive action toward the elimination of discriminatory practices in the sale, rental, financing and all other housing transactions;

WHEREAS, the Richland County Council recognizes the County Administrator as the Fair Housing Administrator for Richland County; and

WHEREAS, The Fair Housing Administrator recognizes the Community Development Department as the official coordinator of all Fair Housing initiatives on behalf of Richland County; and

NOW, THEREFORE, BE IT RESOLVED, that Richland County Council is a partner of The United States Department of Housing and Urban Development, acknowledges Fair Housing as one of the nations most cherished and fundamental values and proclaims April 2011 as Fair Housing Month.

SIGNED AND SEALED this \_\_\_ day of \_\_\_\_\_, 2011, having been duly adopted by the Richland County Council on the \_\_\_ day of \_\_\_\_\_, 2011.

\_\_\_\_\_  
Paul Livingston, Chair  
Richland County Council

ATTEST this \_\_\_ day of \_\_\_\_\_, 2010

\_\_\_\_\_  
Michielle R. Cannon-Finch  
Clerk of Council

# Richland County Council Request of Action

**Subject**

Community Development Week Proclamation [**PAGE 59**]

**Notes**

March 22, 2011 - The committee recommended that Council approve the request to present the Community Development Week Proclamation at the April 5th Council meeting. The vote in favor was unanimous.

STATE OF SOUTH CAROLINA)

CD WEEK PROCLAMATION

COUNTY OF RICHLAND )

**RICHLAND COUNTY PROCLAIMS APRIL 25-30, 2011 AS  
COMMUNITY DEVELOPMENT (CD) WEEK**

**Whereas**, the Community Development Block Grant (CDBG) Program has operated since 1975 to provide local governments with the resources required to meet the needs of persons of low- and moderate-income, and CDBG funds are used by thousands of neighborhood- based, non-profit organizations throughout the nation to address pressing neighborhood and human service needs; and

**Whereas**, the Community Development Block Grant program has had a significant impact on our local economies through job creation and retention, physical redevelopment and improved local tax bases; and

**Whereas**, City, USA and other local governments have clearly demonstrated the capacity to administer and customize the CDBG program to identify, prioritize and resolve pressing local problems, such as affordable housing, neighborhood and human service needs, job creation and retention and physical redevelopment; and

**Now, Therefore I, Paul Livingston**, by virtue of the authority vested in me as Chairperson Richland County Council, do hereby proclaim the week of **April 25- 30, 2011**, as Richland County **Community Development Week** in Columbia, South Carolina, and urge all citizens to join us in recognizing the Community Development Block Grant program and the important role it plays in our community.

**In Witness Whereof**, I have hereunto set my hand and caused the seal of Richland County to be affixed this 5th day of April 2011.

**SIGNED AND SEALED** this \_\_\_\_ day of \_\_\_\_\_, 2011, having been duly adopted by the Richland County Council on the \_\_\_\_ day of \_\_\_\_\_, 2011.

\_\_\_\_\_

Paul Livingston, Chair  
Richland County Council

ATTEST this \_\_\_\_ day of \_\_\_\_\_, 2010

\_\_\_\_\_  
Michielle R. Cannon-Finch

Clerk of Council

# Richland County Council Request of Action

**Subject**

Budget Amendment for Risk Management [PAGES 62-63]

**Notes**

March 22, 2011 - The committee recommended that Council approve a budget amendment to Risk Management in the amount of \$500,000 to pay liability claims. The vote in favor was unanimous.

First Reading:

Second Reading:

Third Reading:

Public Hearing:

STATE OF SOUTH CAROLINA  
COUNTY COUNCIL FOR RICHLAND COUNTY  
ORDINANCE NO. \_\_-11HR

AN ORDINANCE AMENDING THE FISCAL YEAR 2010-2011 GENERAL FUND ANNUAL BUDGET TO APPROPRIATE \$500,000 OF GENERAL FUND UNDESIGNATED FUND BALANCE TO RISK MANAGEMENT FOR THE COUNTY'S LIABILITY CLAIMS.

Pursuant to the authority granted by the Constitution and the General Assembly of the State of South Carolina, BE IT ENACTED BY THE COUNTY COUNCIL FOR RICHLAND COUNTY:

SECTION I. That the amount of five hundred thousand dollars (\$500,000) be appropriated to FY 2010-2011 Risk Management. Therefore, the Fiscal Year 2010-2011 General Fund Annual Budget is hereby amended as follows:

REVENUE

Revenue appropriated July 1, 2010 as amended:	\$ 137,823,215
Appropriation of General Fund undesignated fund balance	<u>500,000</u>
Total General Fund Revenue as Amended:	\$ 138,323,215

EXPENDITURES

Expenditures appropriated July 1, 2010 as amended:	\$ 137,823,215
Increase to Risk Management's Current Budget	<u>500,000</u>
Total General Fund Expenditures as Amended:	\$ 138,323,215

SECTION II. Severability. If any section, subsection, or clause of this ordinance shall be deemed to be unconstitutional or otherwise invalid, the validity of the remaining sections, subsections, and clauses shall not be affected thereby.

SECTION III. Conflicting Ordinances Repealed. All ordinances or parts of ordinances in conflict with the provisions of this ordinance are hereby repealed.

SECTION IV. Effective Date. This ordinance shall be enforced from and after \_\_\_\_\_, 2010.

RICHLAND COUNTY COUNCIL

BY: \_\_\_\_\_  
Paul Livingston, Chair

ATTEST THIS THE \_\_\_\_ DAY

OF \_\_\_\_\_, 2010

\_\_\_\_\_  
Michielle R. Cannon-Finch  
Clerk of Council

RICHLAND COUNTY ATTORNEY'S OFFICE

\_\_\_\_\_  
Approved As To LEGAL Form Only.  
No Opinion Rendered As To Content.

First Reading:  
Second Reading:  
Public Hearing:  
Third Reading:

# Richland County Council Request of Action

## **Subject**

An Ordinance Amending the Fiscal Year 2010-2011 General Fund Annual Budget to appropriate \$164,754 of General Fund Undesignated Fund Balance to the Solicitor for additional funding for emergency budget request [**PAGES 65-66**]

## **Notes**

February 22, 2011 - The committee recommended that Council approve the Solicitor's emergency budget request in the amount of \$164,754. The vote was in favor.

First Reading: March 1, 2011  
Second Reading: March 15, 2011  
Third Reading:  
Public Hearing:



STATE OF SOUTH CAROLINA  
COUNTY COUNCIL FOR RICHLAND COUNTY  
ORDINANCE NO. \_\_-11HR

AN ORDINANCE AMENDING THE FISCAL YEAR 2010-2011 GENERAL FUND ANNUAL BUDGET TO APPROPRIATE \$164,754 OF GENERAL FUND UNDESIGNATED FUND BALANCE TO THE SOLICITOR FOR ADDITIONAL FUNDING FOR EMERGENCY BUDGET REQUEST.

Pursuant to the authority granted by the Constitution and the General Assembly of the State of South Carolina, BE IT ENACTED BY THE COUNTY COUNCIL FOR RICHLAND COUNTY:

SECTION I. That the amount of one hundred sixty four thousand seven hundred fifty four dollars (\$164,754) be appropriated to FY 2010-2011 Solicitor. Therefore, the Fiscal Year 2010-2011 General Fund Annual Budget is hereby amended as follows:

REVENUE

Revenue appropriated July 1, 2010 as amended:	\$ 137,823,215
Appropriation of General Fund undesignated fund balance	<u>164,754</u>
Total General Fund Revenue as Amended:	\$ 137,987,969

EXPENDITURES

Expenditures appropriated July 1, 2010 as amended:	\$ 137,823,215
Increase to Solicitor's Current Budget	<u>164,754</u>
Total General Fund Expenditures as Amended:	\$ 137,987,969

SECTION II. Severability. If any section, subsection, or clause of this ordinance shall be deemed to be unconstitutional or otherwise invalid, the validity of the remaining sections, subsections, and clauses shall not be affected thereby.

SECTION III. Conflicting Ordinances Repealed. All ordinances or parts of ordinances in conflict with the provisions of this ordinance are hereby repealed.

SECTION IV. Effective Date. This ordinance shall be enforced from and after \_\_\_\_\_, 2010.

RICHLAND COUNTY COUNCIL

BY: \_\_\_\_\_  
Paul Livingston, Chair

ATTEST THIS THE \_\_\_\_ DAY

OF \_\_\_\_\_, 2010

\_\_\_\_\_  
Michielle R. Cannon-Finch  
Clerk of Council

RICHLAND COUNTY ATTORNEY'S OFFICE

\_\_\_\_\_  
Approved As To LEGAL Form Only.  
No Opinion Rendered As To Content.

First Reading:  
Second Reading:  
Public Hearing:  
Third Reading:

# Richland County Council Request of Action

**Subject**

Hopkins Community Water System Elevated Tank Color and Logo **[PAGES 68-73]**

**Notes**

March 22, 2011 - The committee recommended Council approve staff's recommendation of the tank logo detail as presented in option "A" with the tank color "Teardrop". The vote was in favor.

## Richland County Council Request of Action

**Subject:** Hopkins Community Water System  
Elevated Tank Color and Logo

**A. Purpose**

The purpose of this report is to seek County Council’s approval of the color and logo for the elevated water storage tank being constructed as part of the Hopkins Community Water System.

**B. Background**

County Council has previously approved the construction of the Hopkins Community Water System and an elevated tank construction contract with Caldwell Tanks. The tank is currently under construction with only the final color and logo to be determined.

**C. Discussion**

The design engineer has provided four color / logo options for consideration. The logo as presented in an adaptation of the County Seal and the County logo “Uniquely Urban, Uniquely Rural”.

**D. Financial Impact**

The selection of one of the offered color / logo options will have no financial impact on the project.

**E. Alternatives**

1. Council may approve Staff’s recommended options.
2. Council may select an alternative option from those presented.
3. Council may elect to redesign the color / logo scheme.

**F. Recommendation**

It is Staff’s recommendation that the tank logo detail as presented in option “A” with tank color “Teardrop” be approved by County Council.

**Recommended by:** Andy H. Metts    **Department:** Utilities    **Date** 3/8/11

**G. Reviews**

Please indicate your recommendation with a  before routing to the next recipient. Thanks.

**Finance**

Reviewed by: Daniel Driggers

Date: 3/8/11

Recommend Council approval

Recommend Council denial

Comments regarding recommendation: Recommendation based on Utility Director’s comments.

**Procurement**

Reviewed by: Rodolfo Callwood

Date: 3/9/11

Recommend Council approval  
denial

Recommend Council

Comments regarding recommendation:

**Legal**

Reviewed by: Larry Smith

Date:

Recommend Council approval

Recommend Council denial

Comments regarding recommendation:

**Administration**

Reviewed by: Sparty Hammett

Date: 3/10/11

Recommend Council approval

Recommend Council denial

Comments regarding recommendation: Recommend approval of Option A.

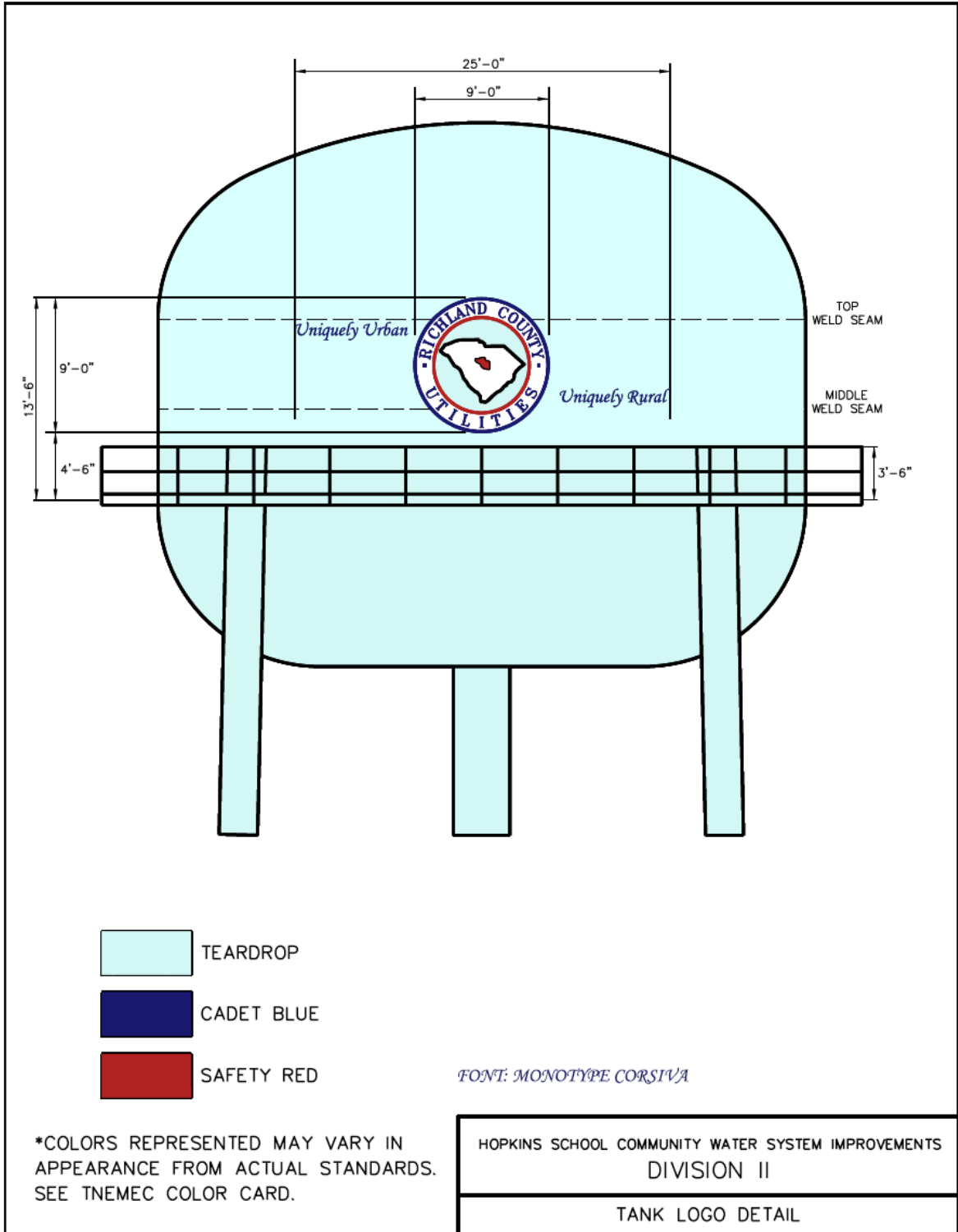

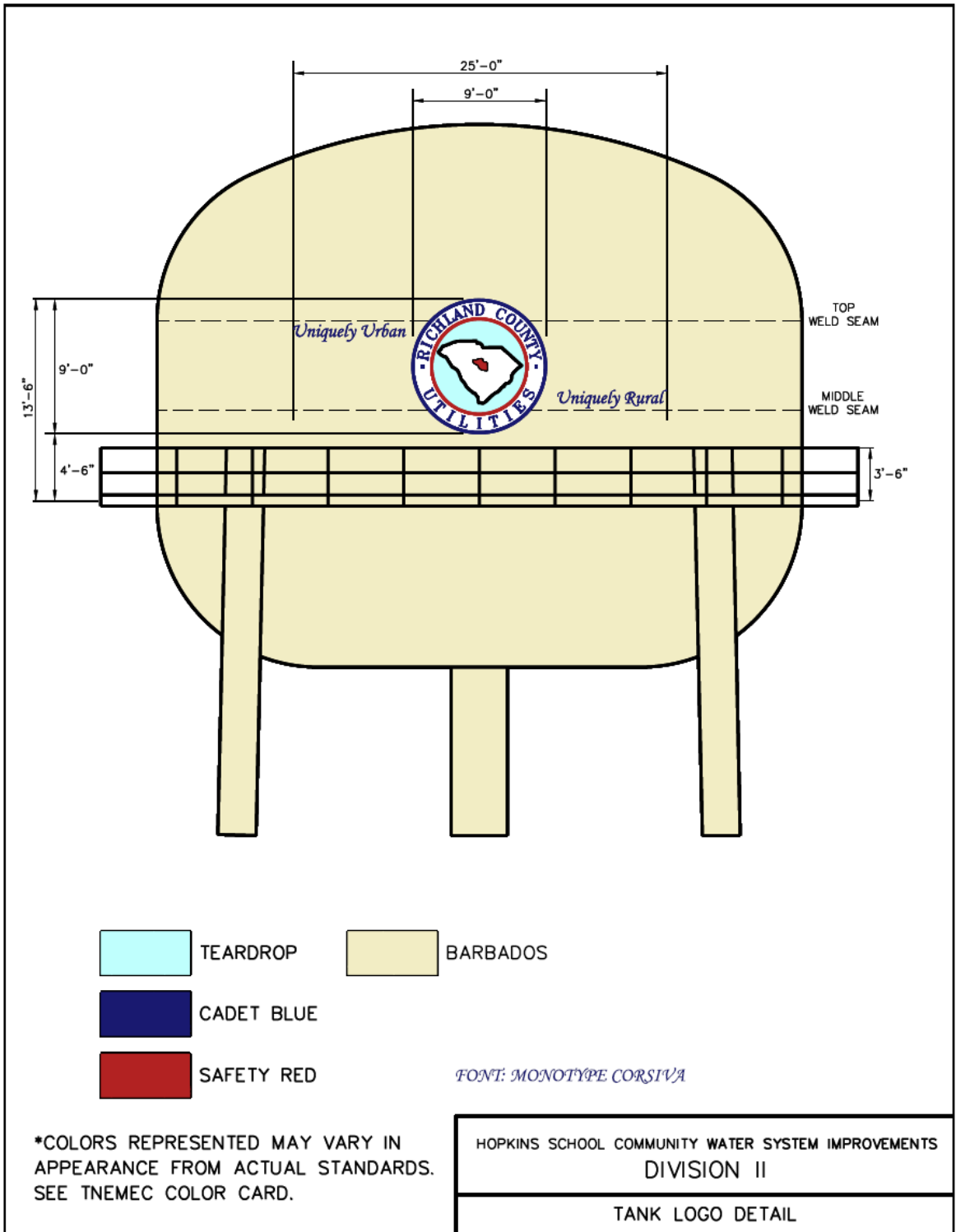

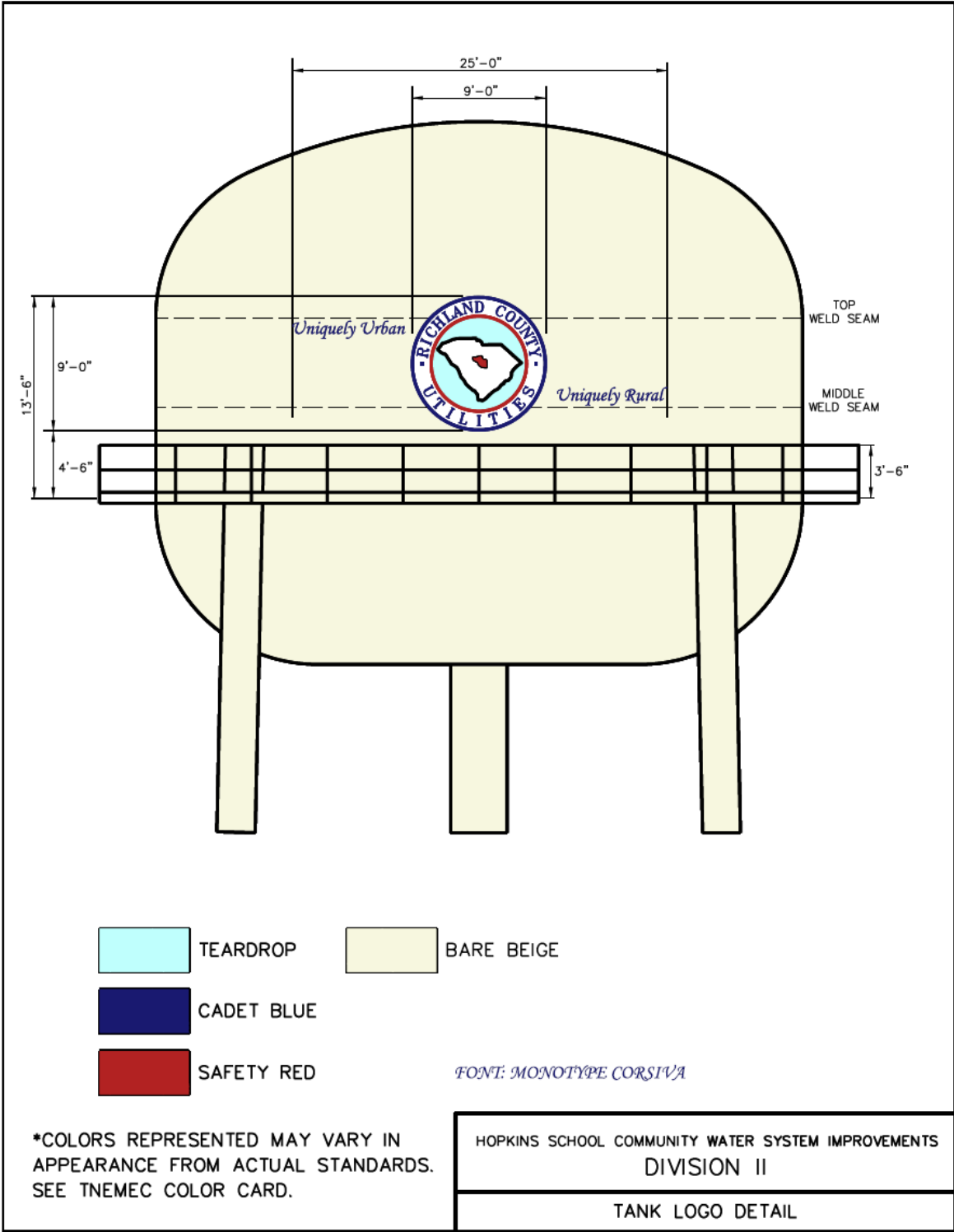



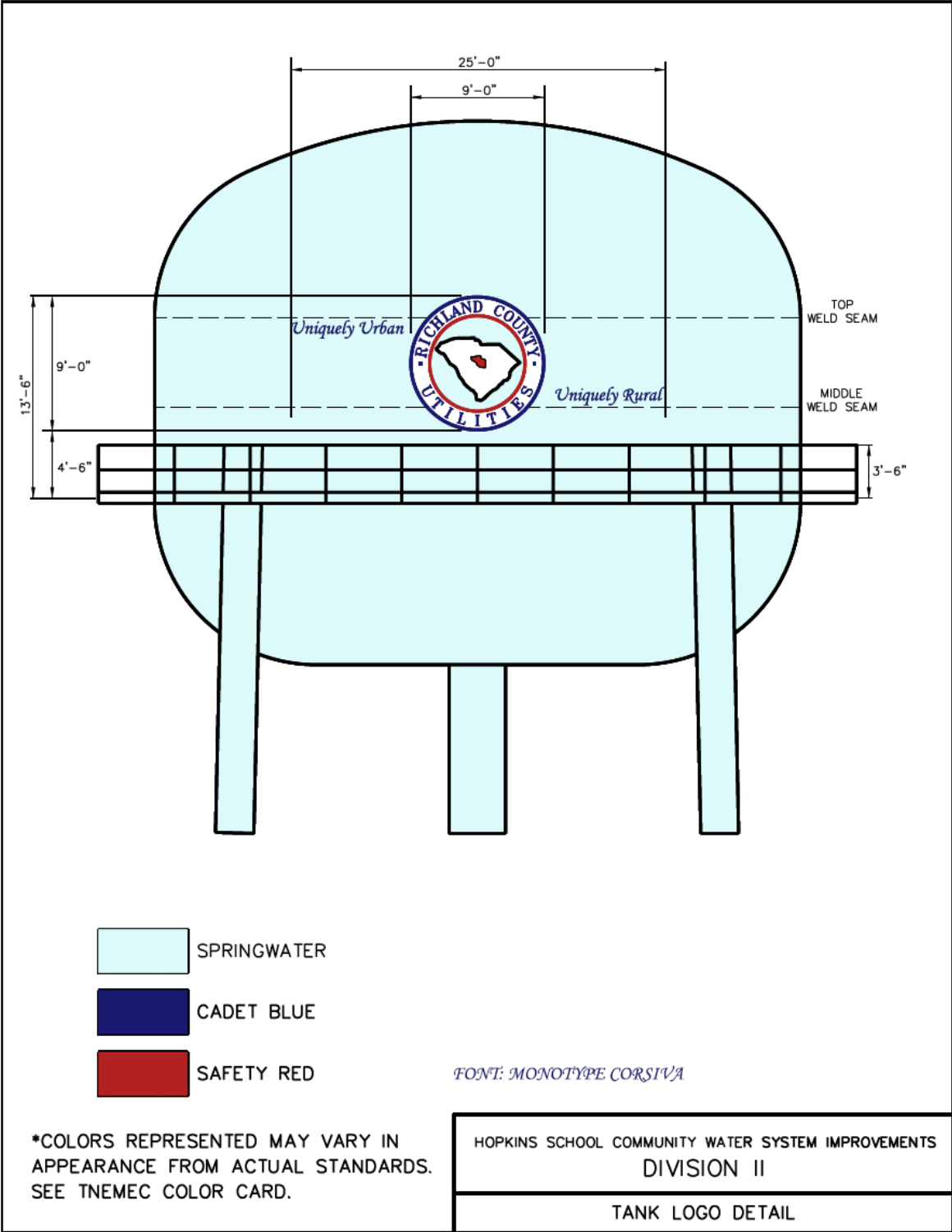

# Richland County Council Request of Action

## **Subject**

An Ordinance Authorizing a Utility Easement/Right-of-Way to South Carolina Electric & Gas Company on property identified as TMS # 25600-03-16, also known as 199 Newland Road **[PAGES 75-82] [FIRST READING]**

## **Notes**

March 22, 2011 - The committee voted to send this item to Council without a recommendation and directed staff to provide Council with a detailed map of the easement. The vote was in favor.

First Reading:

Second Reading:

Third Reading:

Public Hearing:

# Richland County Council Request of Action

**Subject:** Power Line Easement to SCE&G

**A. Purpose**

County Council is requested to approve an easement to SCE&G for power line placement along the eastern boundary of property owned by the County.

**B. Background / Discussion**

The Legal Department was approached by SCE&G (Paulette Ritter, Right-of-Way agent) about acquiring an easement for a power line along the eastern property line of a parcel owned by the county. The property is located at the end of Newland Road and was deeded to the County by New Small Clemson, LLC for storm drainage/detention pond.

Please see the attached easement and plat to further identify location of the requested easement.

**C. Financial Impact**

There is no known financial impact with this request.

**D. Alternatives**

1. Grant the easement to SCE&G (approve the attached ordinance)
2. Do not grant the easement to SCE&G (do not approve the attached ordinance)

**E. Recommendation**

It is recommended that Council approve the request for easement.

Recommended by: Elizabeth McLean

Department: Legal

Date: 3/8/11

**F. Reviews**

(Please **SIGN** your name, ✓ the appropriate box, and support your recommendation before routing. Thank you!)

**Finance**

Reviewed by: Daniel Driggers

Date: 3/8/11

✓ Recommend Council approval

Recommend Council denial

Comments regarding recommendation:

**Public Works**

Reviewed by: David Hoops

Date: 3/9/11

X  Recommend Council approval

Recommend Council denial

Comments regarding recommendation:

**Legal**

Reviewed by: Larry Smith

✓ Recommend Council approval

Comments regarding recommendation:

Date:

Recommend Council denial

**Administration**

Reviewed by: Sparty Hammett

✓ Recommend Council approval

Comments regarding recommendation:

Date: 3/10/11

Recommend Council denial

STATE OF SOUTH CAROLINA  
COUNTY COUNCIL FOR RICHLAND COUNTY  
ORDINANCE NO. \_\_\_\_\_-11HR

AN ORDINANCE AUTHORIZING A UTILITY EASEMENT/RIGHT-OF-WAY TO SOUTH CAROLINA ELECTRIC & GAS COMPANY ON PROPERTY IDENTIFIED AS TMS# 25600-03-16, ALSO KNOWN AS 199 NEWLAND ROAD.

Pursuant to the authority granted by the Constitution of the State of South Carolina and the General Assembly of the State of South Carolina, BE IT ENACTED BY RICHLAND COUNTY COUNCIL:

SECTION I. The County of Richland and its employees and agents are hereby authorized to grant a utility easement right-of-way to South Carolina Electric & Gas Company, upon land identified as TMS Number 25600-03-16, located at 199 Newland Road, and as is more fully described in the easement/right-of-way, a copy of which is attached hereto and incorporated herein.

SECTION II. Severability. If any section, subsection, or clause of this ordinance shall be deemed unconstitutional or otherwise invalid, the validity of the remaining sections, subsections, and clauses shall not be affected thereby.

SECTION III. Conflicting Ordinances. All ordinances or parts of ordinances in conflict with the provisions of this ordinance are hereby repealed.

SECTION IV. Effective Date. This ordinance shall be effective from and after \_\_\_\_\_, 2011.

RICHLAND COUNTY COUNCIL

By: \_\_\_\_\_  
Paul Livingston, Chairperson

Attest this \_\_\_\_\_ day of  
\_\_\_\_\_, 2011.

\_\_\_\_\_  
Michielle R. Cannon-Finch  
Clerk of Council

RICHLAND COUNTY ATTORNEY'S OFFICE

---

Approved As To LEGAL Form Only  
No Opinion Rendered As To Content

First Reading:  
Second Reading:  
Public Hearing:  
Third reading:

INDENTURE, made this \_\_\_\_\_ day of \_\_\_\_\_, 2011 by and between County Council of Richland of the County of Richland and State of South Carolina, hereinafter called "Grantor" (whether singular or plural), and the SOUTH CAROLINA ELECTRIC & GAS COMPANY, a South Carolina corporation, having its principal office in Cayce, South Carolina, hereinafter called "Grantee".

WITNESSETH:

That, in consideration of the sum of One Dollar (\$1.00) received from Grantee, Grantor, being the owner of land situate in the County of Richland, State of South Carolina, hereby grants and conveys to Grantee, its successors and assigns, the right to construct, extend, replace, relocate, perpetually maintain and operate an overhead or underground electric line or lines consisting of any or all of the following: poles, conductors, lightning protective wires, municipal, public or private communication lines, cables, conduits, pad mounted transformers, guys, push braces and other accessory apparatus and equipment deemed by Grantee to be necessary or desirable, upon, over, across, through and under land described as follows: a tract or lot of land containing 1.59 acres, more or less, and being the same lands conveyed to Grantor by deed of Newsmall Clemson, LLC, dated or recorded 10/29/2002, and filed in the Register of Deeds office for Richland County in Deed Book 718 at Page 2120.

Right of Way granted for overhead primary line as shown on Exhibit A and is by reference only made a part hereof.

TMS: 25600-03-16

Together with the right from time to time to install on said line such additional lines, apparatus and equipment as Grantee may deem necessary or desirable and the right to remove said line or any part thereof.

Together also with the right (but not the obligation) from time to time to trim, cut or remove trees, underbrush and other obstructions that are within, over, under or through a strip of land ("Easement Space") extending Fifteen (15) feet on each side of any pole lines or other devices as they are installed; provided, however, any damage to the property of Grantor (other than that caused by trimming, cutting or removing) caused by Grantee in maintaining or repairing said lines, shall be borne by Grantee; provided further, however, that Grantors agree for themselves, their successors and assigns, not to build or allow any structure to be placed on the premises in such a manner that any part thereof will exist within the applicable above specified Easement Space, and in case such structure is built, then Grantor, or such successors and assigns as may be in possession and control of the premises at the time, will promptly remove the same upon demand of Grantee herein. Together also with the right of entry upon said lands of Grantor for all of the purposes aforesaid.

The words "Grantor" and "Grantee" shall include their heirs, executors, administrators, successors and assigns, as the case may be.

IN WITNESS WHEREOF, Grantor has caused this indenture to be duly executed the day and year first above written.

WITNESS:

County Council of Richland

\_\_\_\_\_  
1<sup>st</sup> Witness

By:  
Title:

\_\_\_\_\_  
(SEAL)

\_\_\_\_\_  
2nd Witness

RW-4-E-SC-C (Rev. 4-2010)

Item# 21

Attachment number 1  
Page 5 of 7

**State of South Carolina** )  
 )  
**County of Richland** )

Personally appeared before me the undersigned witness, and made oath that (s)he saw the within named **County Council of Richland** by the hand of \_\_\_\_\_ sign, seal and as its act and deed deliver the within easement for the uses and purposes therein mentioned, and that (s)he with the other subscribing witness, witnessed the due execution thereof.

Sworn to before me this \_\_\_\_\_ day of \_\_\_\_\_ (1<sup>st</sup> Witness)  
\_\_\_\_\_ A.D., 2011.

\_\_\_\_\_  
Notary Public for South Carolina (L.S.)

My Commission Expires \_\_\_\_\_

**RIGHT OF WAY GRANT TO  
SOUTH CAROLINA ELECTRIC & GAS COMPANY**

Line: **Monkey Joes - Newland Road**

County: **Richland**

R/W File Number: **16952**

Grantor(s): **County Council of Richland**

Return to: **SCE&G  
Paulette T. Ritter - J29  
Columbia, SC 29218**

RW-4-E-SC-C (Rev. 4-2010)

Item# 21

Attachment number 1  
Page 6 of 7



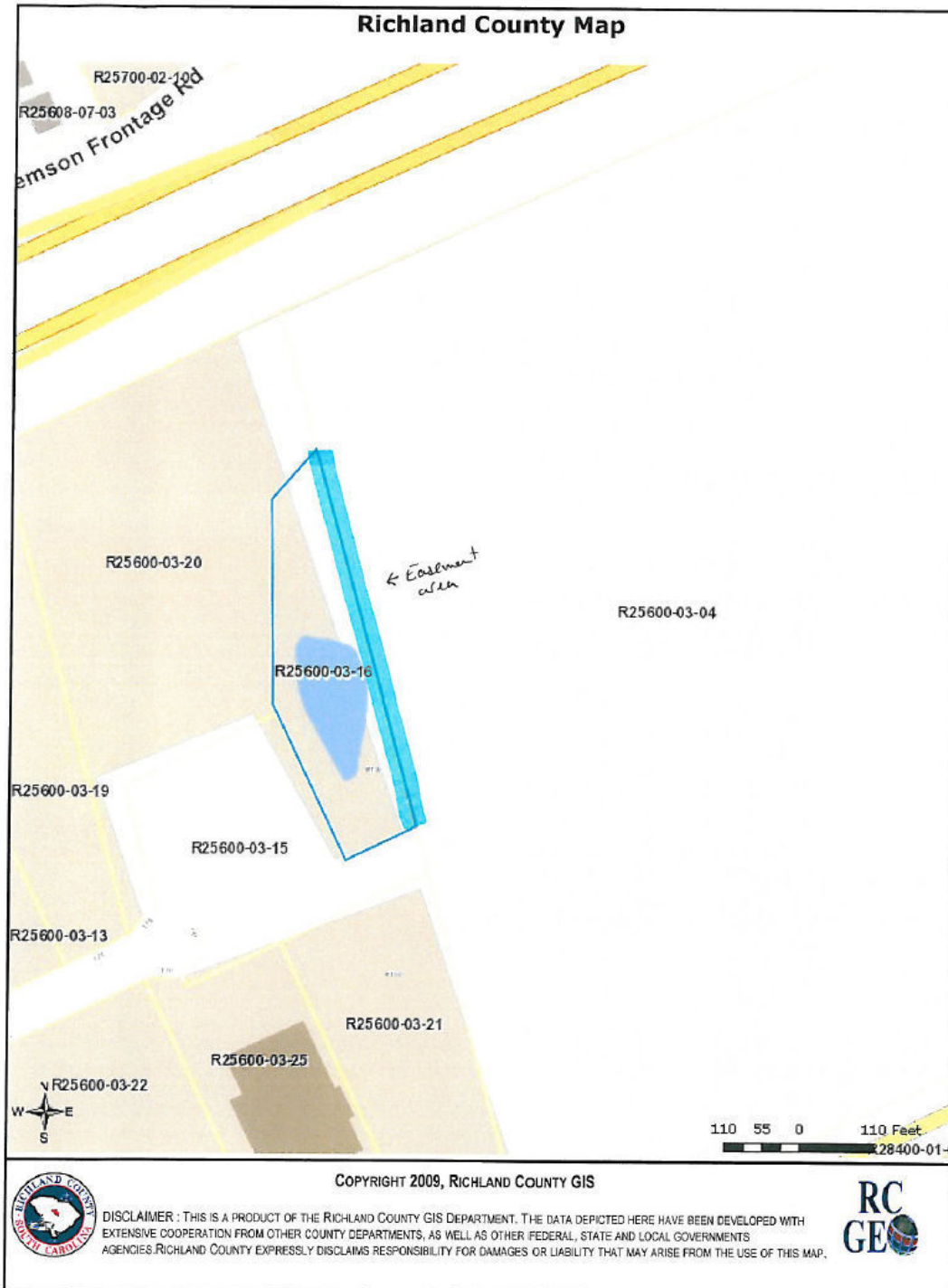

# SCE&G Requested Easement on County Property



**DISCLAIMER:** This is a product of the Richland County Public Works Department. The data depicted here have been developed with extensive cooperation from other county departments, as well as other federal, state and local government agencies. Reasonable efforts have been made to ensure the accuracy of this map. Richland County expressly disclaims responsibility for damages or liability that may arise from the use of this map.

**PROPRIETARY INFORMATION:** Any resale of this information is prohibited, except in accordance with a licensing agreement.

**COPYRIGHT** ©2011  
Richland County Public Works  
400 Powell Rd.  
Columbia, SC 29203

Item# 21

Attachment number 2  
Page 1 of 1

# Richland County Council Request of Action

**Subject**

Research and give alternative transportation options for released inmates [PAGES 84-85]

**Notes**

March 22, 2011 - The committee recommended that Council re-establish the Ad-Hoc Jail committee to identify drop-off points. The vote was in favor.

## **Richland County Council Request of Action**

**SUBJECT:** Research and Give Alternative Transportation Options for Released Inmates

### **A. PURPOSE**

Councilman Rose made a motion on February 15, 2011 for staff to research and give alternative options for the transportation of inmates being released from the Alvin S. Glenn Detention Center (ASGDC). Currently, inmates without transportation are being transported and dropped off at the CMRTA bus station on Laurel Street (one block from City Hall and Main Street).

### **B. BACKGROUND / DISCUSSION**

The release of inmates without transportation has been a long standing issue for Richland County and the ASGDC. In 1995, when the ASGDC opened its doors at the Bluff Road Facility, a promise was made to the community that released inmates would not be allowed to walk down Bluff Road.

Several years ago, the Detention Center refused to accept a detainee from a City of Columbia Police Officer due to his medical condition. The officer released the detainee by summons and the inmate was allowed to walk down Bluff Road. The inmate was hit by a car as he walked down the road, and later died from his injuries.

The ASGDC is far from public transportation and it is not safe to walk down Bluff Road for the following reasons: (1) limited visibility during darkness or inclement weather and (2) the small road shoulder. As a result, a decision was made to take the inmates to an agreed drop-off point to allow for public transportation.

The following sites were discontinued due to the limited availability of buses.

- George Rogers Boulevard and Bluff Road
- Rosewood Drive at the Fairground

The follow locations have been inmate drop off points and were discontinued due to complaints from the City of Columbia, and the business community.

- The corner of Assembly and Lady Street
- The corner of Assembly and Taylor (Oliver Gospel Mission)

The current drop-off point is the corner of Laurel and Sumter Street (Bus Transfer Center). Previously, the County had a Ad Hoc Jail Committee that helped address operational issues. The Detention Center requests for County Council to re-establish the Ad Hoc Jail Committee to review the current way inmates are released from the jail without transportation and come up with a recommendation that will best serve the community.

**C. FINANCIAL IMPACT**

No additional funding required.

**D. ALTERNATIVES**

1. Re-establish Ad Hoc Jail Committee to indentify drop-off points.
2. Allow the County Administrator and the Detention Center to meet with City Officials to come up with alternatives.
3. Continue with the current operational procedures in place.

**E. RECOMMENDATION**

Staff recommends approval of Option 1 – Re-establish Ad Hoc Jail Committee to identify drop-off points.

Recommended by: Ronaldo Myers Department: Detention Center Date: March 14, 2011

**F. Reviews**

(Please **SIGN** your name, ✓ the appropriate box, and support your recommendation before routing. Thank you!)

**Finance**

Reviewed by Daniel Driggers

Date: 3/15/11

✓ Recommend Council approval

Recommend Council denial

Comments regarding recommendation:

**Legal**

Reviewed by: Larry Smith

Date:

✓ Recommend Council approval

Recommend Council denial

Comments regarding recommendation:

**Administration**

Reviewed by: Sparty Hammett

Date: 3/17/11

✓ Recommend Council approval

Recommend Council denial

Comments regarding recommendation: Recommend Option #1.

# Richland County Council Request of Action

**Subject**

Video Streaming and Rebroadcast of Council Meetings [**PAGES 87-88**]

**Notes**

March 22, 2011 - The committee recommended that if Council chooses to move forward with this project that it direct staff to conduct further research and provide a financial recommendation in time for the 2011/2012 budget cycle. The vote was in favor.

# Richland County Council Request of Action

**Subject:** Video Streaming and Rebroadcast of Council Meetings

## **A. Purpose**

The purpose of this request of actions is to provide an analysis to County Council of the resources and costs that would be associated with video streaming council meetings live via the county website and rebroadcasting council meetings on the county's cable channel.

## **B. Background / Discussion**

On February 1, 2011 Richland County Council approved a motion directing county staff to research the viability and costs that would be associated with streaming council meetings live via the website and review the resources that would be needed to videotape council meetings for rebroadcast on the county's cable channel.

It is significant to note that currently no broadcast infrastructure exists in Council Chambers and it is recommended that if Council chooses to move forward, then the following modifications and or equipment purchases are recommended by the Office of Public Information and Information Technology:

- I. Cameras (3)
- II. High Definition Broadcast Video/Live Streaming Production System (One Stop Shop)
- III. Upgrading of existing sound system to provide a separate mix for up to 16 mic inputs
- IV. Hosting for Video Streaming
- V. Video Archival System

\*It is also important to note that all local governments currently streaming video and rebroadcasting council meetings have made significant infrastructure investments in cameras, audio, production and editing equipment. These comparable communities include Charleston, North Charleston, as well as the City of Columbia.

## **C. Financial Impact**

It is estimated that the financial impact of purchasing the equipment to both video stream and broadcast council meetings would be approximately \$51,000.

## **D. Alternatives**

List the alternatives to the situation.

1. Council may choose to stream council meetings live and rebroadcast meetings on Richland County Cable Channel 2.

- Council may choose not to stream council meetings live or rebroadcast meetings on Richland County Cable Channel 2.

## E. Recommendation

It is recommended that if council chooses to move forward with this project that it directs county staff to conduct further research and provide a financial recommendation in time for the 2011/2012 budget cycle.

Analysis Provided by: Stephany Snowden      Department: PIO      Date: 02/08/2011

## F. Reviews

(Please **SIGN** your name, ✓ the appropriate box, and support your recommendation before routing. Thank you!)

### Finance

Reviewed by: Daniel Driggers

Date: 2/9/11

Recommend Council approval

Recommend Council denial

Comments regarding recommendation: Council discretion. Approval would require the identification of funding.

### Procurement

Reviewed by: Rodolfo Callwood

Date: 2/10/11

Recommend Council approval

Recommend Council denial

Comments regarding recommendation:

### Grants

Reviewed by: Sara Salley

Date: 2/10/11

Recommend Council approval

Recommend Council denial

Comments regarding recommendation: Council discretion

### Legal

Reviewed by: Larry Smith

Date:

Recommend Council approval

Recommend Council denial

Comments regarding recommendation: Council discretion

### Administration

Reviewed by: J. Milton Pope

Date: 2-10-11

Recommend Council approval

Recommend Council denial

Comments regarding recommendation: Recommend denial/deferral of this item at this time and request that Council finalize its policy position on the matter. If approved the financing of the request should be moved to the FY 12 Budget process.



# Richland County Council Request of Action

**Subject**

Caughman Creek Property [**UNDER SEPARATE COVER**]

**Notes**

March 22, 2011 - The committee moved this from an item for discussion/information to an action item. This item was then forwarded to Council without a recommendation. The vote in favor was unanimous.

# Richland County Council Request of Action

**Subject**

Business Service Center Appeals Board-1 [William (Bill) West, May 6, 2011\*]

# Richland County Council Request of Action

**Subject**

Community Relations Council-1 [one application was received from Seneca Brewton Henry] [**PAGES 92-93**]

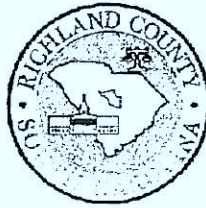

**APPLICATION FOR SERVICE ON RICHLAND COUNTY COMMITTEE, BOARD OR COMMISSION**

**Applicant must reside in Richland County.**

Name: Seneca Brewton Henry

Home Address: 113 Walters Rd Irmo, SC 29063

Telephone: (home) 803-781-5742 (work) 803-927-3484

Office Address: 1708-B Richland St. Columbia, 29201

Email Address: Senecahenry09@yahoo.com

Educational Background: USC, Columbia, SC - M.Ed.

Professional Background: Social services, education, employment, legal, disability

Male  Female  Age: 18-25  26-50  Over 50

Name of Committee in which interested: Community Relations Council

Reason for interest: I want to promote what is extra-ordinary about the Midlands and play a role in addressing what needs

Your characteristics/qualifications, which would be an asset to Committee, Board or improvement.

Commission:

I have experience working in related issues.

Presently serve on any County Committee, Board or Commission? No

Any other information you wish to give? \_\_\_\_\_

Recommended by Council Member(s): \_\_\_\_\_

Hours willing to commit each month: open

**CONFLICT OF INTEREST POLICY**

It is the policy of Richland County to require disclosure of any personal or financial interest that may be influenced by decisions of the Committee, Board or Commission for which any citizen applies for membership.

Such conflict of interest does not preclude service but shall be disclosed before appointment. The Clerk of Council shall be notified of any change on an annual basis and members of all

Committees, Boards or Commissions shall be required to abstain from voting or influencing through discussion or debate, or any other way, decisions of the Committee, Board or Commission affecting those personal and financial interests.

All statements so filed shall be signed and verified by the filer. The verification shall state that the filer has used all reasonable diligence in its preparation, and that to the best of his or her knowledge, it is true and complete.

Any person who willfully files a false or incomplete statement of disclosure or no change of condition, or who willfully fails to make any filing required by this article, shall be subject to such discipline, including censure and disqualification from the Committee, Board or Commission, by majority vote of the council.

*Have you been convicted or pled no contest of a crime other than minor traffic violations; checking yes does not automatically preclude you from consideration for appointment.*

Yes \_\_\_\_\_ No X

**STATEMENT OF FINANCIAL OR PERSONAL INTERESTS**

Do you have any financial or personal interest in any business or corporation (profit or not-for-profit) that could be potentially affected by the actions of the Committee, Board or Commission?

Yes \_\_\_\_\_ No X

If so, describe: \_\_\_\_\_  
\_\_\_\_\_  
\_\_\_\_\_

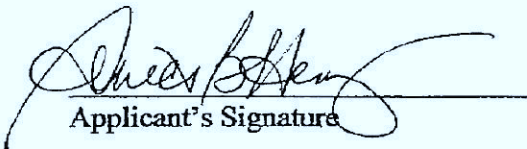
  
Applicant's Signature

9-16-10  
Date

**Return to:**  
**Clerk of Council, Post Office Box 192, Columbia, SC 29202.**  
**For information, call 576-2060.**

**One form must be submitted for each Committee, Board or Commission on which you wish to serve.**

**Applications are current for one year.**

Staff Use Only	
Date Received: _____	Received by: _____
Date Sent to Council: _____	
Status of Application: <input type="checkbox"/> Approved <input type="checkbox"/> Denied <input type="checkbox"/> On file	

# Richland County Council Request of Action

**Subject**

Employee Grievance Committee-1 [one application was received from Vivian McCray\*] [**PAGES 95-97**]



**APPLICATION FOR SERVICE ON RICHLAND COUNTY  
COMMITTEE, BOARD OR COMMISSION**

Name: Vivian McCray

Home Address: 137 Manorwood Court # C, Columbia, SC 29212

Telephone: (home) (803) 397-8942 (work) (803) 576-2044

Office Address: 2020 Hampton Street, Suite 3063, Columbia, SC 29204

Email Address: mccrayv@rcgov.us

Educational Background: Master of Arts Degree – Human Behavior & Conflict Management

Professional Background: Volunteer Mediator; Housing Project Coordinator

Male  Female  Age: 18-25  26-50  Over 50

Name of Committee in which interested: Grievance Committee

Reason for interest: Utilize training as a Mediator. Continue to serve as Vice Chair until new election.

Your characteristics/qualifications, which would be an asset to Committee, Board or Commission:

Expertise as previous Committee member; training in Mediation. Great listening skills.

Presently serve on any County Committee, Board or Commission? Grievance Committee

Any other information you wish to give? No

Recommended by Council Member(s): \_\_\_\_\_

Hours willing to commit each month: 5 hours

**CONFLICT OF INTEREST POLICY**

It is the policy of Richland County to require disclosure of any personal or financial interest that may be influenced by decisions of the Committee, Board or Commission for which any citizen applies for membership.

Such conflict of interest does not preclude service but shall be disclosed before appointment. The Clerk of Council shall be notified of any change on an annual basis and members of all

Committees, Boards or Commissions shall be required to abstain from voting or influencing through discussion or debate, or any other way, decisions of the Committee, Board or Commission affecting those personal and financial interests.

All statements so filed shall be signed and verified by the filer. The verification shall state that the filer has used all reasonable diligence in its preparation, and that to the best of his or her knowledge, it is true and complete.

Any person who willfully files a false or incomplete statement of disclosure or no change of condition, or who willfully fails to make any filing required by this article, shall be subject to such discipline, including censure and disqualification from the Committee, Board or Commission, by majority vote of the council.

*Have you been convicted or pled no contest of a crime other than minor traffic violations; checking yes does not automatically preclude you from consideration for appointment.*

Yes \_\_\_\_\_ No X \_\_\_\_\_

**STATEMENT OF FINANCIAL OR PERSONAL INTERESTS**

Do you have any financial or personal interest in any business or corporation (profit or not-for-profit) that could be potentially affected by the actions of the Committee, Board or Commission?

Yes \_\_\_\_\_ No X \_\_\_\_\_

If so, describe: Not aware of any.  
\_\_\_\_\_  
\_\_\_\_\_

Therian McCray  
Applicant's Signature

3/7/2011  
Date

**Return to:**  
**Clerk of Council, Post Office Box 192, Columbia, SC 29202.**  
**For information, call 576-2060.**

**One form must be submitted for each Committee, Board or Commission on which you wish to serve.**

**Applications are current for one year.**

Staff Use Only		
Date Received: _____	Received by: _____	
Date Sent to Council: _____		
Status of Application:	<input type="checkbox"/> Approved	<input type="checkbox"/> Denied <input type="checkbox"/> On file

2

Item# 27



# Richland County Council Request of Action

**Subject**

Planning Commission-1 [applications were received from the following persons: Patrick Palmer; Herbert Sims; Elizabeth Mattos-Ward; Jack R. Ward, Jr.]

# Richland County Council Request of Action

**Subject**

If Council intends to attempt another try at a Referendum for a penny sales tax increase, all council members shall hold public meetings to get public input before making a final decision whether to move forward or not. Public input shall determine how proceeds from the tax will be spent and the term of the tax. This process should be given enough time to make sure it does not appear rushed or at the last minute **[JACKSON] [PAGES 99-104]**

**Reason:**

If approved, the citizens will be paying for this and we are only the representatives of the people's will and so we shall do everything that's in the best interest of the people we serve.

**Transparency:**

This process whether it is approved and passes or not will give comfort to our constituents that we are not hiding anything by revealing up front everything that would be done with that tax.

Completed	Business - Contact Name	Date Requested	Time Request	Location	Requested Topics	Actual Date	Speaker	Email	Phone	Notes
✓	Sustainable Midlands - Ryan Nevius	August 5th	3:00pm	Capital Senior Center	asking for a presentation re: 1 cent transportation tax referendum		Stephany	<a href="mailto:nvan@sustainablemidlands.org">nvan@sustainablemidlands.org</a>		
✓	Forest Acres Rotary Club - Mark Williams	August 18th	12:30pm	Golden Corral on Forest Drive	asking for a presentation re: 1 cent transportation tax referendum		Rox, Milton	<a href="mailto:mwilliams@forestacres.net">mwilliams@forestacres.net</a>	803-782-9475	
✓	GOP Meeting - Bob Barnwell	August 23 - Monday	6:00pm	Suggs & Kelly	Transportation Penny		Milton, Rox, Steph	<a href="mailto:sctrojanbob@gmail.com">sctrojanbob@gmail.com</a>		
✓	WACH Media Presentation	August 24th	10:00am	WACH Fox, Pickens St			PIO			
✓	United Way's CEO Association - Lila Anna Sauls	August 25th - Wednesday	9:30am	Trinity Cathedral, Sumter St (Corner of Marion & Gervais), 3rd Floor	"What does a Penny get you"		Mr. Pope	<a href="mailto:lasauls@stlawrenceplace.org">lasauls@stlawrenceplace.org</a>	256-3999	Requested Mr. Pope
✓	Transportation Study Commission Meeting	August 25th	2:30pm	Columbia College			Milton, Rox, Steph			
✓	WIS Media Presentation	August 26th	8:30 am & 3:00pm	WIS, 1111 Bull St			PIO			
✓	WLTX - Allen Wallace	August 27th - Friday	7:00 PM	WLTX Studio	Transportation Penny		Roxanne	<a href="mailto:jwallace@wltx.gannett.com">jwallace@wltx.gannett.com</a>	Cell- 706-267-0959 Office 803-776-9508 ext. 234	
✓	WIS TV - Brandi Cummings	August 31 - Tuesday	11:00 AM	Richland County Admin			Roxanne			

Completed	Business - Contact Name	Date Request	Time Requested	Location	Requested Topics	Actual Date	Speaker	Email	Phone	Notes	Notes
✓	Brandon Acres/Cedar Terrace Community - Tige Watts	September 9th, Thursday	7:00PM - 8:15PM	Hampton Park, 1117 Brandon Ave	Penny Transportation Presentation		Roxanne	<a href="mailto:jigewatts@aol.com">jigewatts@aol.com</a>	237-3396	We will need to provide a laptop projector and screen for presentation	Park contact person Delores Salley 776-9082 or 766-1415
✓	Citizens for a Greater Midlands - Betty Gregory	September 14, Tuesday	9:30am - 11am	Chamber of Commerce - Old Print Room - First Floor	Speakers Training Briefing		Milton, Rox	<a href="mailto:betygregory@columbiachamber.com">betygregory@columbiachamber.com</a>	206-0759 (cell) or 733-2520 (office)		
✓	WLTX	September 14, Tuesday	9:30am - 10:30am	Wltx Studio	Educational Briefing		Stephany				
✓	The State - Dawn Hinsaw	September 14, Tuesday	2:00pm to 3:00 pm	Roxanne's Office - Conference Call	Discuss Roads projects		Roxanne				
✓	Business Association of Columbia - Banks Lowry	September 15th - Wednesday	7:30am - 8:30 am	The Summit Club / Wilbur Smith Building	General info regarding sales tax increase		Milton	<a href="mailto:blowry@mcwaters.com">blowry@mcwaters.com</a>	803-212-4218 or cell 803-603-8543		
✓	Transportation Penny Educational Session	September 15th - Wednesday	6:00 pm - 7:00 pm	Harbison Recreation Center			Milton, Rox, Steph				
✓	Transportation Penny Educational Session	September 16th - Thursday	6:00 pm - 7:00 pm	RCSD Lower Richland Regional 1 Headquarters			Roxanne				
✓	The State Newspaper - Warren Bolton	September 21st - Tuesday	9:30am - 10:30am	The State Newspaper Offices			Roxanne, Milton				
✓	Transportation Penny Educational Session	September 22nd - Wednesday	6:00 pm - 7:00 pm	Parklane Adult Activity Center			Rox, Steph, Tamara				
✓	RC Neighborhood Council - Erica Hink	September 23, 2010	6:30 PM	Council Chambers	how the tax will work, Prioritized projects, etc		Milton	<a href="mailto:rjobrien_col@bellsouth.net">rjobrien_col@bellsouth.net</a>	576-1340		
✓	Old Leesburg Community - Crime Watch Meeting - Shirley Mims	September 23 - Thursday	7:00 pm - 8:00pm	Mt. Olive Church, 5601 Old Leesburg Rd., Hopkins SC							
✓	Transportation Penny Educational Session	September 27th - Monday	6:00 pm - 7:00 pm	Richland County Public Library	Transportation Penny Sales Tax		Stephany Rox, Steph,	<a href="mailto:Mimss@rcgov.us">Mimss@rcgov.us</a>	576-2446		
✓	WISTV	September 30 - Thursday	2:45PM - 3:45PM	1111 Bull St	Media Presentation		Rox	<a href="mailto:rstander@wistv.com">rstander@wistv.com</a>			

Completed	Business - Contact Name	Date Request	Time Request	Location	Requested Topics	Actual Date	Speaker	Email	Phone
✓	Lower Richland Democratic Breakfast - Rev. Neal Jones	October 2 - Saturday	9:00 AM	Lizards Thicket - 7938 Garners Ferry Rd SC Dept of Archives & History, 8301 Parklane Rd, Columbia SC 29223	Transportation Penny Sales Tax Presentation		Roxanne	<a href="mailto:nealjoness@sc.ir.com">nealjoness@sc.ir.com</a>	
✓	Neighborhood Planning Conference Columbia Capital Foy	October 2 - Saturday	8:30 AM - 2:00 PM	Palmetto Club	Booth on Transportation Sales Tax		Stephany & Tamara		227-4822
✓	County/City Joint Transportation Sales Penny Presentation - Councilman Jackson & Councilwoman Plaugh (city)	October 6th - Wednesday	7:20 AM - 7:50 AM	Woodland Park	Transportation Penny Sales Tax Presentation		Milton		
✓	Chamber of Commerce - Mr. Campbell	October 13th - Saturday	6:30 PM	Chamber of Commerce	Joint County/City Transportation Penny Sales Presentation		Stephany	<a href="mailto:snowdens@rcgov.us">snowdens@rcgov.us</a>	576-2065
✓	NE - Lake Carolina / The Summit	October 14 - Thursday	12:00 PM to 12:15 PM	Lake Carolina Sales Office	Transportation Penny Presentation to Area Ministers (Educational Only)		Milton		446-2670
✓	League of Women Voters - Lill Mood	October 20 - Wednesday	6:30 PM - 7:30 PM	Capital Senior Center	Advocacy Group request: wants RC staff person there for factual information if needed.		Milton		
✓	Awareness Taping - Brandi Cummings	October 21st - Thursday	11:00 AM-12:30 PM	WIS Station	Transportation Penny Sales Tax Presentation		Roxanne	<a href="mailto:lrwood@bellsouth.net">lrwood@bellsouth.net</a>	
✓	College Place area and Bethlem Baptist Church - Kendall Corey	October 21st - Thursday	11:00 AM - 11:30AM	Family Life Center, 1028 Eastman St, Columbia	Transportation Penny Sales Tax Presentation		Mr. Popel Stephary		
✓	On Point on Fox w/ Cynthia Hardy	October 21st - Thursday	6:30 PM	WACH Fox, Pickens St	Transportation Sales Tax Presentation		Stephany	<a href="mailto:dc@thecampbellconsultinggroup.net">dc@thecampbellconsultinggroup.net</a>	727-8190
	Forest Lake Recreation Center - James Manning	October 22 - Friday	3:45 PM	Forest Lake Recreation Center	Transportation Sales Tax Presentation		Stephany		
	Forest Acres Neighborhood Association - Beth Baldauf	October 26th - Tuesday	6:30 PM - 7:00 PM	St. Michael & All Angels' Episcopal Church, 6408 Bridgewood Rd (Corner of Bridgewood & N. Trenholm)	Penny Transportation Presentation		Steph	<a href="mailto:jamesmanning@gmail.com">jamesmanning@gmail.com</a>	386.8242
	Rotary Club - Ebony Woods	October 26th - Tuesday	7:00 PM	Lutheran Seminary (across from Hyatt Park Elem on N. Main) in the cafeteria	Transportation Penny Sales Tax Presentation		Rox	<a href="mailto:beth.baldauf@gmail.com">beth.baldauf@gmail.com</a>	
	NE - Woodcreek, Wildwood	October 26th - Tuesday	7:30 AM - 8:30 AM	Wildwood Community Center	Transportation Penny Sales Tax Presentation			<a href="mailto:woods@rcgov.us">woods@rcgov.us</a>	576-2048
	Retired Military - Russell Anderson	October 27 - Wednesday	6:30 PM - 7:30 PM	NCO club on Ft. Jackson	Advocacy Group request: wants RC staff person there for factual information if needed.		Rox		
	Richland Radio	October 29 - Friday	8:00 AM - 9:00 AM	Richland Radio	Transportation Penny Sales Tax Presentation		Milton		360-7178
	Heyward Bannister - Election Day Training	October 29 - Friday	5:00 PM - 6:00 PM	Chamber of Commerce	Richland Radio		Rox, Milton Steph		
	Heyward Bannister - Election Day Training	October 30 - Saturday	10:00 AM - 11:30 AM	Chamber of Commerce	Heyward Bannister - Election Day Training		Rox		
	Heyward Bannister - Election Day Training	October 30 - Saturday	12:00 PM - 1:30 PM	Chamber of Commerce	Heyward Bannister - Election Day Training		Rox		
	Council Member Washington	October 30 - Saturday	9:00 AM - 12:00 PM	Hopkins Park	Heyward Bannister - Election Day Training		Steph		

**List of Speakers**  
Roxanne Ancheta

**Department**  
Administration

**Date / Time Preference**  
Any day / time except Tuesday afternoon and evenings

Completed	Business - Contact Name	Date Requested	Time Request	Location	Requested Topics	Actual Date	Speaker	Email	Phone	Notes
✓	Sustainable Midlands - Ryan Nevius	August 5th	3:00pm	Capital Senior Center	asking for a presentation re: 1 cent transportation tax referendum		Stephany	<a href="mailto:ryan@sustainablemidlands.org">ryan@sustainablemidlands.org</a>		
✓	Forest Acres Rotary Club - Mark Williams	August 18th	12:30pm	Golden Corral on Forest Drive	asking for a presentation re: 1 cent transportation tax referendum		Rox, Milton	<a href="mailto:mwilliams@forestacres.net">mwilliams@forestacres.net</a>	803-782-9475	
✓	WACH Media Presentation	August 24th	10:00am	WACH Fox, Pickens St			PIO Milton, Rox, Steph			
✓	Transportation Study Commission Meeting	August 25th	2:30pm	Columbia College WIS, 1111 Bull St			PIO			
✓	WIS Media Presentation	August 26th	8:30 am & 3:00pm				PIO			
✓	Business Association of Columbia - Banks Lowry	September 15th - Wednesday	7:30am - 8:30 am	The Summit Club / Wilbur Smith Building	General info regarding sales tax increase		Milton	<a href="mailto:blowry@mcwaters.com">blowry@mcwaters.com</a>	803-212-4218 or cell 803-603-8543	
✓	WIS 1 V - Brandi Cummings - Awareness	October 21st - Thursday	11:00 AM	WIS, 1111 Bull St	Milton on Penny Tax		Milton			
✓	RC Neighborhood Council - Erica Hink	September 23, 2010	6:30 PM	Council Chambers	how the tax will work, Prioritized projects, etc		Milton	<a href="mailto:robrien_col@bellsouth.net">robrien_col@bellsouth.net</a>	576-1340	
✓	League of Women Voters - Lill Mood	October 21st - Thursday	11:45AM - 1:00 PM	Capital Senior Center	Transportation Penny Sales Tax Presentation		Roxanne Milton, Rox, Steph	<a href="mailto:lhmoor@bellsouth.net">lhmoor@bellsouth.net</a>		
✓	GOP Meeting - Bob Barnwell	August 23 - Monday	6:00pm	Suggs & Kelly	Transportation Penny		Trinity Cathedral, Sumter St (Corner of Marion & Gervais,) 3rd Floor	<a href="mailto:stcrojanbob@gmail.com">stcrojanbob@gmail.com</a>		
✓	United Way's CEO Association - Lila Anna Sauls	August 25th - Wednesday	9:30am		"What does a Penny get you"		Mr. Pope	<a href="mailto:lasauls@stlawrenceplace.org">lasauls@stlawrenceplace.org</a> <a href="mailto:jwallace@wltx.gannett.com">jwallace@wltx.gannett.com</a>	256-3999 Cell- 706-267-0959 Office 803-776-9508 ext. 234	Requested Mr. Pope as speaker
✓	WLTX - Allen Wallace	August 27th - Friday	7:00 PM	WLTX Studio	Transportation Penny		Rox			
✓	Brandon Acres/Cedar Terrace Community - Tige Watts	September 9th, Thursday	7:00PM - 8:15PM	Hampton Park, 1117 Brandon Ave	Penny Transportation Presentation		Rox	<a href="mailto:tigewatts@aol.com">tigewatts@aol.com</a>	237-3396	We will need to provide a laptop projector and screen for presentation
✓	WIS TV - Brandi Cummings	August 31 - Tuesday	11:00 AM	Richland County Admin			Roxanne Milton, Rox, Steph			Park contact person Delores Salley 776-9082 or 766-1415
✓	Transportation Penny Educational Session	September 15th - Wednesday	6:00 pm - 7:00 pm	Harbison Recreation Center			Rox, Steph			
✓	Transportation Penny Educational Session	September 16th - Thursday	6:00 pm - 7:00 pm	RCSD Lower Richland Regional 1 Headquarters			Rox, Steph			
✓	Transportation Penny Educational Session	September 22nd - Wednesday	6:00 pm - 7:00 pm	Parklane Adult Activity Center			Rox, Steph, Tamara			
✓	Transportation Penny Educational Session	September 27th - Monday	6:00 pm - 7:00 pm	Richland County Public Library			Rox, Steph			
✓	Citizens for a Greater Midlands - Betty Gregory	September 14, Tuesday	9:30 - 11 or 2 to 3:30	Chamber of Commerce - Old Print Room - First Floor	Speakers Training Briefing		Rox, Milton	<a href="mailto:bettygregory@columbiachamber.com">bettygregory@columbiachamber.com</a>	206-0759 (cell) or 733-2520(office)	
✓	The State - Dawn Hinsaw	September 14, Tuesday	2:00pm to 3:00 pm	Roxanne's Office - Conference Call	Discuss Roads projects		Roxanne			
✓	WLTX	September 14, Tuesday	9:30am - 10:30am	Wltx Studio	Educational Briefing		Stephany Rox, Steph, Milton			
✓	The State Newspaper - Warren Bolton	September 21st - Tuesday	9:30am - 10:30am	The State Newspaper Offices						
✓	Old Leesburg Community - Crime Watch Meeting - Shirley Mims	September 23 - Thursday	7:00 pm - 8:00pm	Mt. Olive Church, 5601 Old Leesburg Rd., Hopkins SC	Transportation Penny Sales Tax		Stephany	<a href="mailto:Mimss@rcgov.us">Mimss@rcgov.us</a>	576-2446	
✓	Lower Richland Democratic Breakfast - Rev. Neal Jones	October 2, Saturday	9:00 AM	Lizards Thicket - 7938 Garners Ferry Rd	Transportation Penny Sales Tax Presentation		Rox	<a href="mailto:nealjoness@sc.rr.com">nealjoness@sc.rr.com</a>		
✓	County/City Joint Transportation Sales Penny Presentation - Councilman Jackson & Councilwoman Plaugh (city)	October 13th, Saturday	6:30 PM	Woodland Park	Joint County/City Transportation Penny Sales Presentation		Rox, Milton, Steph	<a href="mailto:snowdens@rcgov.us">snowdens@rcgov.us</a>	576-2065	
✓	Carolina News	September 23, Thursday	9:30 AM	Admin Office	Interview re ISI for Carolina News (USC Media Program)		Rox			
✓	Forest Acres Neighborhood Association - Beth Baldauf	October 26th - Tuesday	7:00 PM	St. Michael & All Angels' Episcopal Church, 6408 Bridgewood Rd (Corner of Bridgewood & N. Trenholm)	Transportation Penny Sales Tax Presentation		Rox	<a href="mailto:beth_baldauf@gmail.com">beth_baldauf@gmail.com</a>		
✓	Columbia Capital Rotary Club - Darren Foy	October 6th - Wednesday	7:20 AM - 7:50 AM	Palmetto Club	Transportation Penny Sales Tax Presentation		Milton		227-4822	
✓	WISTV	September 30 - Thursday	2:45PM - 3:45PM	1111 Bull St	Media Presentation		Rox	<a href="mailto:rstander@wistv.com">rstander@wistv.com</a>		
✓	Chamber of Commerce - Mr. Campbell	October 14 - Thursday	12:00 PM to 12:15 PM	Chamber of Commerce	Transportation Penny Presentation to Area Ministers (Educational Only)		Rox		446-2670	
✓	NE - Lake Carolina / The Summit	October 20 - Wednesday	6:30 PM - 7:30 PM	Lake Carolina Sales Office	Advocacy Group request; wants RC staff person there for factual information if needed.		Rox			
✓	NE - Woodcreek, Wildwood College Place area and Bethlehem Baptist Church - Kendall Corely	October 27 - Wednesday	6:30 PM - 7:30 PM	Wildwood Community Center	Advocacy Group request; wants RC staff person there for factual information if needed.		Rox			
✓	On Point on Fox w/ Cynthia Hardy	October 21st - Thursday	6:30 PM	Family Life Center, 1028 Eastman St, Columbia	Transportation Sales Tax Presentation			<a href="mailto:dc@thecampbellconsultinggroup.net">dc@thecampbellconsultinggroup.net</a>	727-8190	
✓	Forest Lake Recreation Center - James Manning	October 22 - Friday	3:45 PM	WACH Fox, Pickens St	Transportation Sales Tax Presentation		Stephany			
✓	Forest Lake Recreation Center - James Manning	October 26th - Tuesday	6:30 PM - 7:00 PM	Forest Lake Recreation Center	Penny Transportation Presentation		Steph Rox, Milton, Steph	<a href="mailto:jamesmanningsc@gmail.com">jamesmanningsc@gmail.com</a>	803.386.8242	
✓	Richland Radio	October 29 - Friday	5:00 PM - 6:00 PM	Richland Radio	Richland Radio					
✓	Heyward Bannister - Election Day Training	October 30 - Saturday	10:00 AM - 11:30 AM	Chamber of Commerce	Heyward Bannister - Election Day Training		Rox			
✓	Heyward Bannister - Election Day Training	October 30 - Saturday	12:00 PM - 1:30 PM	Chamber of Commerce	Heyward Bannister - Election Day Training		Rox			
✓	Rotary Club - Ebony Woods	October 26th - Tuesday	7:30 AM - 8:30 AM	Lutheran Seminary (across from Hyatt Park Elem on N. Main) in the cafeteria	Transportation Penny Sales Tax Presentation			<a href="mailto:woodse@rcgov.us">woodse@rcgov.us</a>	576-2048	
✓	Council Member	October 30 - Saturday	9:00 AM - 12:00 PM	Hopkins Park			Steph			
✓	Washington Retired Military - Russell Anderson	October 29 - Friday	8:00 AM - 9:00 AM	NCO club on Ft Jackson	Transportation Penny Sales Tax Presentation		Milton		360-7178	

Completed	Business - Contact Name	Date Requested	Time Request	Location	Requested Topics	Actual Date	Speaker	Email	Phone	Notes
	Florence & Hutcheson Consulting EGINEERS - Suzie Sale Dennis Corporation	Would like some between 9/6 - 9/8	between 9am and 11am	Florence & Hutcheson, 501 Huger St	Transportation Penny			<a href="mailto:ssale@flohut.com">ssale@flohut.com</a>	254-5800	



# Richland County Council Request of Action

**Subject**

That all Ordinance changes and text amendments be reflected on the County website no later than 30 days after approval by Council. Presently some ordinance changes that law enforcement may have a need for do not reflect current wording [**MALINOWSKI**]

# Richland County Council Request of Action

**Subject**

All motions shall be made from Council members only and any request or modification or amendments from staff should be sponsored by a Council member. All changes or addition to any document shall be highlighted or shown in a different color **[JACKSON]**

# Richland County Council Request of Action

**Subject**

Manage the number of motions made by Council members during the Motion Period **[LIVINGSTON]**

# Richland County Council Request of Action

**Subject**

All checkmarks placed for recommendation or denial of a particular item on the Council agenda will require a comment to show why such decision was made (No more blanks) **[MALINOWSKI]**

# Richland County Council Request of Action

**Subject**

That all meeting Council members are advised of will automatically be placed on those Council members calendars who request this service, whether or not they "accept" the invite **[MALINOWSKI]**

# Richland County Council Request of Action

**Subject**

In light of some recent FOIA requests staff should create a policy addressing requests stating they are in the interest of the public and, therefore, the requester should not be charged. Just because a media person or attorney makes a request does not automatically make it in the interest of the public. It should be incumbent on the requester to show that **[MALINOWSKI]**

# Richland County Council Request of Action

**Subject**

Personnel Matter: Evaluation Forms [**PAGES 112-122**]

## Richland County Administrator Performance Evaluation

### Instructions

This evaluation form contains seven categories of evaluation criteria. Each category contains statements to describe the performance standards within that category. For each statement in the first six categories, use the following rating scale to indicate your rating of the County Administrator's performance.

3 = Exceeds the performance standard

2 = Meets the performance standard

1 = Does not meet the performance standard

NR = The evaluator chooses not to rate the Administrator on this element

All ratings of "1" and "3" must be justified with specific example of poor or exemplary performance. For example, for the performance standard "Cooperates with neighboring communities and other local governments," an example of poor or substandard performance may be "the administrator refused to meet with a task force of local governments addressing area transportation issues". An example of performance that exceeds expectations for that same standard may be "the administrator took the initiative to form and spearhead a task force to address an economic development opportunity".

If you do not know enough about the Administrator's performance in an area or otherwise do not feel comfortable in assigning a rating, please indicate that by placing "NR" next to the rating element. No items should be left blank.

This form also includes an opportunity for narrative responses to open-ended questions and any other information you believe is pertinent to the evaluation. Please write legibly or use an electronic version of this form.

Leave all pages of this form attached. All evaluations submitted prior to the deadline will be summarized and presented to the County Administrator by a committee of Council.

**Signature:** \_\_\_\_\_



- 3 = Exceeds the performance standard
- 2 = Meets the performance standard
- 1 = Does not meet the performance standard
- NR = The evaluator chooses not to rate the Administrator on this element

**Council Relations**

- \_\_\_\_\_ Carries out directives of the council as a whole as opposed to any one member or action.  
Works through the chair or vice-chair appropriately
- \_\_\_\_\_ Disseminates complete and accurate information requested by the full council to all members in a timely manner
- \_\_\_\_\_ Assists council by facilitating decision-making without usurping authority
- \_\_\_\_\_ Takes initiative to provide information, advice and recommendations to the council on non-routine matters
- \_\_\_\_\_ Responds to and follows up on requests from council members
- \_\_\_\_\_ Acts upon advice and constructive criticism from council members

Please justify any "1" or "3" ratings and give specific examples of unacceptable or outstanding performance.

---



---



---

**Policy Execution**

- \_\_\_\_\_ Implements council actions in accordance with the intent of council
- \_\_\_\_\_ Supports council actions both inside and outside the organization after a decision has been reached
- \_\_\_\_\_ Supports and enforces the county's laws, ordinances and policies
- \_\_\_\_\_ Reviews ordinances and policies periodically to suggest improvements to their effectiveness
- \_\_\_\_\_ Offers workable alternatives to the council for changes in laws or policies that are no longer effective

Please justify any "1" or "3" ratings and give specific examples of unacceptable or outstanding performance.

---



---



---

- 3 = Exceeds the performance standard*
- 2 = Meets the performance standard*
- 1 = Does not meet the performance standard*
- NR = The evaluator chooses not to rate the Administrator on this element*

**Staff Management**

- \_\_\_\_\_ Recruits and retains competent personnel to staff positions
- \_\_\_\_\_ Encourages department heads to make decisions within their jurisdictions with minimal county administrator involvement, yet maintains control of operations
- \_\_\_\_\_ Motivates staff to maximum performance by setting goals and objectives, evaluating progress and providing feedback
- \_\_\_\_\_ Demonstrates teamwork, innovation and effective problem-solving among staff members and other county officials
- \_\_\_\_\_ Promotes training and development opportunities for staff members

Please justify any "1" or "3" ratings and give specific examples of unacceptable or outstanding performance.

---



---



---

**Fiscal Management**

- \_\_\_\_\_ Prepares a balanced budget to provide services at a level directed by council
- \_\_\_\_\_ Makes the best possible use of available funds, being aware of the need to operate county government efficiently and effectively
- \_\_\_\_\_ Produces budget documents and financial reports in an understandable and accessible format to council
- \_\_\_\_\_ Ensures actions and decisions reflect responsible financial planning and accountability
- \_\_\_\_\_ Monitors and manages the fiscal activities and condition of the county

Please justify any "1" or "3" ratings and give specific examples of unacceptable or outstanding performance.

---



---



---

- 3 = Exceeds the performance standard
- 2 = Meets the performance standard
- 1 = Does not meet the performance standard
- NR = The evaluator chooses not to rate the Administrator on this element

**Community/Governmental Relations**

- \_\_\_\_\_ Discusses concerns with and strives to understand the interests of members of the community; resolves issues with citizens
- \_\_\_\_\_ Avoids unnecessary controversy when addressing difficult issues facing the county
- \_\_\_\_\_ Cooperates with neighboring communities and other local governments
- \_\_\_\_\_ Cooperates with regional, state and federal government agencies
- \_\_\_\_\_ Cooperates with elected and appointed Richland County officials
- \_\_\_\_\_ Maintains a non-partisan approach in dealing with the media

Please justify any "1" or "3" ratings and give specific examples of unacceptable or outstanding performance.

---



---



---

**Personal Characteristics**

- \_\_\_\_\_ Maintains knowledge of current developments affecting the practice of local government management
- \_\_\_\_\_ Demonstrates flexibility and a willingness to try new ideas and approaches
- \_\_\_\_\_ Sets a professional example by handling affairs of the public office impartially, transparently, and with honesty and integrity
- \_\_\_\_\_ Demonstrates an ability to work with a diverse group of council members, employees and citizens
- \_\_\_\_\_ Makes difficult decisions in the best interests of the county

Please justify any "1" or "3" ratings and give specific examples of unacceptable or outstanding performance.

---



---



---

## Goal Achievement

County Council sets goals at its annual retreat and the County Administrator provides quarterly updates on the progress of those goals. Please rate how the Administrator is performing on achieving the goals set forth by Council by **checking** the statement that best describes the Administrator's performance.

\_\_\_\_\_ The Administrator has not met expectations in achieving the goals set forth by County Council. Not enough progress has occurred. (Please give specific examples of goals on which progress has not met your expectations).

---

---

---

\_\_\_\_\_ The Administrator has met expectations in achieving the goals set forth by County Council. The progress is on target.

\_\_\_\_\_ The Administrator has exceeded expectations in achieving the goals set forth by County Council. Goals are being accomplished ahead of schedule or more successfully than expected. (Please give specific examples of goals on which progress has exceeded your expectations).

---

---

---

## Narrative Comments

What performance area(s) would you identify as most critical for improvement?

What performance area(s) would you identify as very good and recommend be continued?

What suggestions or assistance can you offer the administrator to enhance performance?

What other comments do you have for the administrator for this rating period?

## Richland County Clerk to Council Performance Evaluation

### Instructions

This evaluation form contains six categories of evaluation criteria. Each category contains statements to describe the performance standards within that category. For each statement in the first five categories, use the following rating scale to indicate your rating of the Clerk to Council's performance.

- 3 = Exceeds the performance standard
- 2 = Meets the performance standard
- 1 = Does not meet the performance standard
- N/O = Not observed during this rating period

All ratings of "1" and "3" must be justified with specific example of poor or exemplary performance. For example, for the performance standard "Prepares and distributes agenda packets for council meetings and other official county meetings accurately and in a timely manner," an example of poor or substandard performance may be "the agenda packets have been incomplete and delivered late on several occasions". An example of performance that exceeds expectations for that same standard may be "the agenda packets are always complete, contain information pertaining to agenda items and arrive early".

Any ratings of "1" or "3" without justifications, or any ratings left blank, will be assigned a rating of "2". If you did not observe the duty being performed during the rating period, please indicate that with "N/O".

This form also includes an opportunity for narrative responses to open-ended questions and any other information you believe is pertinent to the evaluation. Please write legibly or use an electronic version of this form.

Leave all pages of this form attached. All evaluations submitted prior to the deadline will be summarized and presented to the Clerk to Council by a committee of Council.

**Signature:** \_\_\_\_\_

- 3 = Exceeds the performance standard*
- 2 = Meets the performance standard*
- 1 = Does not meet the performance standard*
- N/O = Not observed during this rating period*

**Council Meeting Duties**

- \_\_\_\_\_ Prepares and distributes agenda packets for council meetings and other official county meetings accurately and in a timely manner
- \_\_\_\_\_ Prepares public notices and advertisements of council meetings and other official county functions accurately and in a timely manner
- \_\_\_\_\_ Transcribes and prepares council meeting and other official county meeting minutes accurately and in a timely manner
- \_\_\_\_\_ Publishes and indexes council meeting and other official county meeting minutes accurately and in a timely manner

Please justify any “1” or “3” ratings and give specific examples of unacceptable or outstanding performance.

---



---



---

**Records Management Duties**

- \_\_\_\_\_ Files/maintains/distributes official county records and public documents accurately and in a timely manner
- \_\_\_\_\_ Develops/maintains record retention schedules for council records that comply with state statutes
- \_\_\_\_\_ Develops/maintains record filing and retrieval systems (imaging, computerized records, microfilm) so storage space is minimized and records are easily accessible

Please justify any “1” or “3” ratings and give specific examples of unacceptable or outstanding performance.

---



---



---

3 = Exceeds the performance standard  
2 = Meets the performance standard  
1 = Does not meet the performance standard  
N/O = Not observed during this rating period

**Staff Management Duties**

- \_\_\_\_\_ Recruits and retains competent personnel to staff positions
- \_\_\_\_\_ Sustains or improves staff performance by setting goals and objectives, evaluating progress and providing feedback
- \_\_\_\_\_ Promotes training and development opportunities for self and staff members

Please justify any “1” or “3” ratings and give specific examples of unacceptable or outstanding performance.

---

---

---

**Council Assistance Duties**

- \_\_\_\_\_ Maintains council schedule and calendar so council members are aware of meetings and other activities
- \_\_\_\_\_ Monitors the terms of board/commission members and alerts council when appointments need to occur
- \_\_\_\_\_ Ensures council rules are up-to-date
- \_\_\_\_\_ Arranges travel for council members in a cost effective manner
- \_\_\_\_\_ Arranges annual council retreat in a setting that is conducive to conducting business
- \_\_\_\_\_ Composes/types correspondence, letters and other documents for council members accurately and in a timely manner
- \_\_\_\_\_ Prepares the budget for council and clerk’s office accurately and in a timely manner
- \_\_\_\_\_ Prepares financial reports for council members accurately and in a timely manner
- \_\_\_\_\_ Orients new council members effectively and in a timely manner
- \_\_\_\_\_ Ensures there are adequate supplies and equipment available and follows the County procurement policy in purchasing supplies and equipment

Please justify any “1” or “3” ratings and give specific examples of unacceptable or outstanding performance.

---

---

---

- 3 = Exceeds the performance standard*
- 2 = Meets the performance standard*
- 1 = Does not meet the performance standard*
- N/O = Not observed during this rating period*

**Personal Characteristics**

- \_\_\_\_\_ Organizational skills – the Clerk’s office is set up to provide needed services
- \_\_\_\_\_ Written communication skills – documents are understandable, properly formatted and free of errors
- \_\_\_\_\_ Interpersonal/human relations skills – is able to work with all types of personalities
- \_\_\_\_\_ Verbal communication skills – speaks clearly with a professional tone and gets message across
- \_\_\_\_\_ Computer skills - is able to use various software applications to enhance job performance
- \_\_\_\_\_ Time management skills – is able to prioritize activities and manage time effectively
- \_\_\_\_\_ Reliability – can be counted on to get things done in a timely manner
- \_\_\_\_\_ Flexibility – is open to change and various approaches to getting things done
- \_\_\_\_\_ Professionalism – conducts business with diplomacy and honesty; maintains confidences

Please justify any “1” or “3” ratings and give specific examples of unacceptable or outstanding performance.

---

---

---



## **Narrative Comments**

What performance area(s) would you identify as most critical for improvement?

What performance area(s) would you identify as very good and recommend be continued?

What suggestions or assistance can you offer the clerk to enhance performance?

What other comments do you have for the clerk for this rating period?

## **County Clerk to Council Evaluation Process**

Copies of the evaluation form will be distributed to each council member on a quarterly basis. Each council member should review the evaluation form and indicate any performance concerns on the evaluation form. The evaluation forms should be returned to the Institute for Public Service and Policy Research (IPSPR). Although positive feedback is welcome and encouraged, only the evaluation forms with concerns listed must be returned. Forms not returned indicate that performance is on track and there are no concerns. The IPSPR staff will summarize the quarterly evaluations and forward them to the evaluation committee who will provide feedback to the Clerk.

For the annual evaluation, all council members will receive the entire evaluation package and should complete the entire evaluation form with supporting comments and return it to the IPSPR where staff will summarize the ratings. The average rating for each of the rating elements will be reported. If there are ratings of "1" and "3" on the same element, IPSPR staff will contact the council members who assigned those ratings or left ratings blank to ensure the ratings were accurate.

Rating elements/performance standards with an average rating of less than 1.6 will be considered "not meeting the performance standard".

Rating elements/performance standards with an average rating between 1.6 and 2.4 will be considered "meeting the performance standard".

Rating elements/performance standards with an average rating of more than 2.4 will be considered "exceeding the performance standard".

IPSPR staff will prepare a report summarizing the annual evaluation ratings and comments. The report will be sent to the evaluation committee who will meet with the Clerk to review the evaluation.

# Richland County Council Request of Action

**Subject**

**REPORT OF THE CONSOLIDATION - PRIVATIZATION AD HOC COMMITTEE**

- a. Update: Chairman Norman Jackson

# Richland County Council Request of Action

**Subject**

**REPORT OF THE REGIONAL RECREATION COMPLEX AD HOC COMMITTEE [PAGES 125-129]**

- a. M. B. Kahn Construction Company – Work Authorization #2 **[ACTION]**
- b. Funding Recommendations **[ACTION]**



Since 1927

CONSTRUCTION  
MANAGEMENT  
DIVISION

M.B. Kahn Construction Co., Inc.  
P.O. BOX 1179 / COLUMBIA, SC 29202 / PHONE (803) 736-2950 / FAX (803) 736-9501

February 9, 2011

Ms. Roxanne Ancheta  
Assistant to the County Administrator  
Richland County  
P. O. Box 192  
Columbia, South Carolina 29202

**RE: Richland County Recreation / Entertainment Complex  
Work Authorization Number 2**

Ms. Ancheta;

M. B. Kahn is pleased to submit the enclosed proposal for your consideration. This proposal includes services for Site Planning, Schematic Site Design, and associated Program Management services.

We are available to meet with you after you have had a chance to review the enclosed information so that we may respond to any questions you may have relative to the scope and cost. Please let us know if you wish to meet.

Sincerely,  
**M. B. KAHN CONSTRUCTION CO., INC.**  
Construction Management Division

William W. Cram  
Executive Vice President

Enc: Scope of Work; Fee Proposal; Work Authorization

CC: R. Brax



Item# 38

## **RICHLAND COUNTY RECREATION / ENTERTAINMENT COMPLEX**

### **SCOPE OF WORK**

#### **Site Planning / Schematic Site Design**

Site Planning / Schematic Site Design will include importing the current conceptual layout into the base survey file, then making necessary adjustments and manipulations to insure efficiency in design, layout, and operations. Services to be performed in preparing a schematic site design for the sports and entertainment complex include:

- Site Layout
  - Athletic fields; roadways; sidewalks; nature trail; building pad for future multiplex
- Off Site Roadway Improvements
  - Farrow Road
- Utility Design
  - Water; sanitary sewer; storm drainage; detention ponds; site lighting; telecommunications (all schematic, not detailed)
- Grading
  - Conceptual grading design; estimated retaining walls; earthwork quantity analysis
- 3 – D Rendering
  - 3 – D computer graphic model including “fly-around”
- Deliverables
  - Site layout plans, utility plans, and grading plans (all at 1” = 50’ scale, in AutoCADD)
  - Earthwork analysis
  - Schematic site design report

#### **Feasibility Study, Ideation, Program of Elements, and Financial Analysis**

- Update as needed

## Associated Program Management Services

Associated Program Management services will include planning, schematic design oversight and coordination, estimating, value analysis, site layout critique, scheduling, and preparation and presentation of work product.

- Planning
  - Establish meetings as required
  - Coordinate interim design workshop at 50% task completion
- Schematic design oversight and coordination
  - Coordinate Owner requirements with design team
  - Validate program implementation
- Estimating
  - Identify specific components
  - Prepare detailed quantity surveys
  - Perform market price analysis
  - Estimate non-construction costs
  - Estimate soft costs
  - Assess contingency and inflation conditions
- Value analysis
  - Evaluate alternative designs and materials
- Site layout critique
  - Critical analysis of layout, traffic flow, etc.
- Scheduling
  - Develop schematic design phase management schedule
  - Develop design completion management schedule
  - Develop preliminary construction timeline
- Preparation and presentation of work product
  - Present interim report to Richland County
  - Prepare and present draft report to Richland County
  - Prepare and present final report to Richland County
    - Administration
    - Ad-hoc committee
    - County Council
- Deliverables
  - Detailed program cost estimate
  - Draft report
  - Final report
    - Printed copy
    - Power point presentation



**RICHLAND COUNTY RECREATION COMPLEX**  
**Richland County, SC**

**FEE PROPOSAL BREAKDOWN**

Site planning / schematic site design	\$145,000
Feasibility study, ideation, program of elements, financial analysis review	\$13,000
Associated Program Management Services	\$87,000
<b>Total</b>	<b>\$245,000</b>





**RICHLAND COUNTY RECREATION / ENTERTAINMENT COMPLEX**

**WORK AUTHORIZATION FOR PROFESSIONAL SERVICES**

**Richland County Recreation / Entertainment Complex**

**Work Authorization No. 2**

It is agreed to undertake the following work in accordance with the provisions of our Prime Agreement for Professional Services dated April 1, 2010.

---

**Description of Work Authorization:** Site Planning; Schematic Site Design; update Feasibility Study, Ideation and Program of Elements, and Financial Analysis; and associated Program Management Services as described in M.B. Kahn's proposal dated February 9, 2011 (*copy attached*).

**Basis of Compensation / Period of Services:** A fixed fee of Two Hundred Forty-Five Thousand Dollars (\$245,000.00). Services described herein shall be completed in 180 days of the executed work authorization, subject to updates and modifications as the project progresses. Compensation to be paid in six equal monthly installments as the work progresses.

---

Agreed as to scope of services, time schedule, and budget:

\_\_\_\_\_  
For Richland County, South Carolina

\_\_\_\_\_  
Date

\_\_\_\_\_  
For M. B. Kahn Construction Co., Inc.

\_\_\_\_\_  
Date

Attachment: MBK Proposal Dated 02/09/2011 (4 pages)

# Richland County Council Request of Action

## **Subject**

- a. I move that County Council amend the Employee Handbook to include sexual orientation and gender identity as a protected class from discrimination in the hiring process for equal employment opportunities **[ROSE]**
- b. Motion that County Council adopt the attached public accommodations ordinance. This ordinance prohibits entities from discriminating against a citizen because of race, color, religion, sex, age, national origin, familial status, handicap/disability, or sexual orientation. This ordinance is an exact replica of what the City of Columbia passed in 2008 and in the interest of prohibiting discrimination in any form and regional consistency I motion that County Council adopt it as submitted **[ROSE] [PAGES 131-133]**
- c. Ban smoking within a specified distance from a main entrance of a business or public building **[MANNING]**
- d. To review the Pros and Cons of counting prison and/or jail population in the redistricting calculations **[WASHINGTON]**
- e. Resolution supporting Harvest Hope Food Bank's Hold Out for Hunger Day **[PEARCE] [PAGE 134]**
- f. I move that Council direct staff address the proliferation of illegal signs in the County by involving Special Services Department, or any other County departments, to conduct a weekly Tuesday sign sweep along the most littered corridors of the County. All signs, except government and utility signs, in the right-of-way would be considered "litter" and disposed of by the County. In addition, I move that staff work with the Zoning Department to develop a simpler and more effective illegal sign ordinance and bring that back to Council **[HUTCHINSON]**
- g. Richland County adopt the State's travel policy per diem **[JACKSON]**

STATE OF SOUTH CAROLINA  
COUNTY COUNCIL FOR RICHLAND COUNTY  
ORDINANCE NO. \_\_\_\_-11HR

AN ORDINANCE AMENDING THE RICHLAND COUNTY CODE OF ORDINANCES; CHAPTER 16, LICENSES AND MISCELLANEOUS BUSINESS REGULATIONS; BY THE ADDITION OF ARTICLE VI, EQUAL ENJOYMENT AND PRIVILEGES TO PUBLIC ACCOMMODATIONS; SO AS TO PROHIBIT DISCRIMINATION IN THE EQUAL ENJOYMENT AND PRIVILEGES TO PUBLIC ACCOMMODATIONS.

Pursuant to the authority granted by the Constitution and the General Assembly of the State of South Carolina, BE IT ENACTED BY THE COUNTY COUNCIL FOR RICHLAND COUNTY:

SECTION I. The Richland County Code of Ordinances; Chapter 16, Licenses and Miscellaneous Business Regulations; is hereby amended by the addition of Article VI, Equal Enjoyment and Privileges to Public Accommodations, to read as follows:

**ARTICLE VI. EQUAL ENJOYMENT AND PRIVILEGES TO PUBLIC ACCOMMODATIONS**

**Sec. 16-65. Title.**

This article shall be known and may be cited as the Richland County "Public Accommodations Ordinance."

**Sec. 16-66. Policy.**

It is the policy of Richland County that no person shall be discriminated against in the full and equal enjoyment of the goods, services, facilities, privileges, advantages and accommodations of any place of public accommodation on the basis of race, color, religion, sex, age, national origin, familial status, handicap, disability or sexual orientation.

**Sec. 16-67. Definitions.**

Except where the context clearly indicates otherwise, the following terms as used in this article shall have the following meanings:

*Disability* means a physical or mental impairment that substantially limits one or more of the major life activities of the individual, a record of such an impairment or being regarded as having such an impairment.

*Discrimination* means any direct or indirect act or practice of exclusion, distinction, restriction, segregation, limitation, refusal, denial, or any other act or practice of differentiation or preference in the treatment of a person or persons because of race, color, religion, national origin, age, sex, familial status, handicap,

disability or sexual orientation in the aiding, abetting, inciting, coercing or compelling thereof.

*Place of public accommodation* means any place which serves the public and requires a license or permit issued by the State of South Carolina, its agencies, or Richland County to operate, including, but not limited to:

- (1) Any inn, hotel, motel, or other establishment which provides lodging to transient guests, other than an establishment located within a building which contains not more than five rooms for rent or hire and which is actually occupied by the proprietor of such establishment as his residence;
- (2) Any restaurant, cafeteria, lunchroom, lunch counter, soda fountain, or other facility principally engaged in selling food for consumption on the premises, including, but not limited to, any such facility located on the premises of any retail establishment, or any gasoline station;
- (3) Any hospital, clinic, or other medical facility which provides overnight accommodations;
- (4) Any retail or wholesale establishment;
- (5) Any motion picture house, theater, concert hall, billiard parlor, saloon, barroom, golf course, sports arena, stadium, or other place of amusement, exhibition, recreation, or entertainment; and,
- (6) Any establishment which is physically located within the premises of any establishment otherwise covered by this subsection, or within the premises of which is physically located any such covered establishment, and which holds itself out as serving patrons of such covered establishment.

*Sexual orientation* means a person's real or perceived heterosexuality, homosexuality or bisexuality or gender identity or expression.

**Sec. 16-68. Exemption from public accommodations provisions.**

The provisions of this article do not apply to a private club or other establishment not in fact open to the general public.

**Sec. 16-69. Purpose of law; construction; effect.**

The general purpose of this article is to safeguard all individuals within the unincorporated areas of Richland County from discrimination in the equal enjoyment and privileges to public accommodations because of race, color, religion, national origin, sex, familial status, handicap, disability or sexual orientation; thereby to protect their interest in personal dignity and freedom from humiliation; to secure Richland County against domestic strife and unrest which

would menace its democratic institutions; to preserve the public health and general welfare; and to further the interests, rights, and privileges of individuals within the Richland County.

**Sec. 16-70. Enforcement.**

In addition to appropriate civil and/or equitable remedies for enforcement of this article, a violation of this article shall constitute a misdemeanor punishable as provided by law. Each day of noncompliance with the provisions of this article constitutes a separate and distinct violation.

SECTION II. The Richland County Code of Ordinances; Chapter 16, Licenses and Miscellaneous Business Regulations; Article V, Marriage Licenses; is hereby amended by the addition of the following language to read as follows:

**Secs. 16-62—16-64. Reserved.**

SECTION III. Severability. If any section, subsection, or clause of this ordinance shall be deemed to be unconstitutional or otherwise invalid, the validity of the remaining sections, subsections, and clauses shall not be affected thereby.

SECTION IV. Conflicting Ordinances Repealed. All ordinances or parts of ordinances in conflict with the provisions of this ordinance are hereby repealed.

SECTION V. Effective Date. This ordinance shall be effective from and after \_\_\_\_\_, 2011.

RICHLAND COUNTY COUNCIL

BY: \_\_\_\_\_  
Paul Livingston, Chair

ATTEST THIS THE \_\_\_\_ DAY

OF \_\_\_\_\_, 2011

\_\_\_\_\_  
Michelle R. Cannon-Finch  
Clerk of Council

RICHLAND COUNTY ATTORNEY’S OFFICE

\_\_\_\_\_  
Approved As To LEGAL Form Only  
No Opinion Rendered As To Content



# Richland County Council Request of Action

**Subject**

Must Pertain to Items Not on the Agenda